

**52Xi****Industrial sewing machine**

Instruction manual

**GB**

Betriebsanleitung

**D**

All rights reserved.

Property of Dürkopp Adler AG and copyrighted. Reproduction or publication of the content in any manner, even in extracts, without prior written permission of Dürkopp Adler AG, is prohibited.

*Alle Rechte vorbehalten.*

Eigentum der Dürkopp Adler AG und urheberrechtlich geschützt. Jede, auch auszugsweise Wiederverwendung dieser Inhalte ist ohne vorheriges schriftliches Einverständnis der Dürkopp Adler AG verboten.

**Copyright © Dürkopp Adler AG - 2010**

# Foreword

This instruction manual is intended to help the user to become familiar with the machine and take advantage of its application possibilities in accordance with the recommendations.

The instruction manual contains important information on how to operate the machine securely, properly and economically. Observation of the instructions eliminates danger, reduces costs for repair and down-times, and increases the reliability and life of the machine.

The instruction manual is intended to complement existing national accident prevention and environment protection regulations.

The instruction manual must always be available at the machine/sewing unit.

The instruction manual must be read and applied by any person that is authorized to work on the machine/sewing unit. This means:

- Operation, including equipping, troubleshooting during the work cycle, removing of fabric waste,
- Service (maintenance, inspection, repair) and/or
- Transport.

The user also has to assure that only authorized personnel work on the machine.

The user is obliged to check the machine at least once per shift for apparent damages and to immediately report any changes (including the performance in service), which impair the safety.

The user company must ensure that the machine is only operated in perfect working order.

Never remove or disable any safety devices.

If safety devices need to be removed for equipping, repairing or maintaining, the safety devices must be remounted directly after completion of the maintenance and repair work.

Unauthorized modification of the machine rules out liability of the manufacturer for damage resulting from this.

Observe all safety and danger recommendations on the machine/unit! The yellow-and-black striped surfaces designate permanent danger areas, eg danger of squashing, cutting, shearing or collision.

Besides the recommendations in this instruction manual also observe the general safety and accident prevention regulations!

## General safety instructions

**The non-observance of the following safety instructions can cause bodily injuries or damages to the machine.**

1. The machine must only be commissioned in full knowledge of the instruction book and operated by persons with appropriate training.
2. Before putting into service also read the safety rules and instructions of the motor supplier.
3. The machine must be used only for the purpose intended. Use of the machine without the safety devices is not permitted. Observe all the relevant safety regulations.
4. When gauge parts are exchanged (e.g. needle, presser foot, needle plate, feed dog and bobbin) when threading, when the workplace is left, and during service work, the machine must be disconnected from the mains by switching off the master switch or disconnecting the mains plug.
5. Daily servicing work must be carried out only by appropriately trained persons.
6. Repairs, conversion and special maintenance work must only be carried out by technicians or persons with appropriate training.
7. For service or repair work on pneumatic systems, disconnect the machine from the compressed air supply system (max. 7-10 bar). Before disconnecting, reduce the pressure of the maintenance unit. Exceptions to this are only adjustments and functions checks made by appropriately trained technicians.
8. Work on the electrical equipment must be carried out only by electricians or appropriately trained persons.
9. Work on parts and systems under electric current is not permitted, except as specified in regulations DIN VDE 0105.
10. Conversion or changes to the machine must be authorized by us and made only in adherence to all safety regulations.
11. For repairs, only replacement parts approved by us must be used.
12. Commissioning of the sewing head is prohibited until such time as the entire sewing unit is found to comply with EC directives.
13. The line cord should be equipped with a country-specific mains plug. This work must be carried out by appropriately trained technicians (see paragraph 8).



It is absolutely necessary to respect the safety instructions marked by these signs.

**Danger of bodily injuries !**

Please note also the general safety instructions.



**Introduction and safety instructions****Part 1 - Instructions for use - 52Xi**

<b>1.</b>	<b>Machine description</b> . . . . .	<b>5</b>
<b>2.</b>	<b>Machine use</b> . . . . .	<b>5</b>
<b>3.</b>	<b>Subclasses</b> . . . . .	<b>6</b>
<b>4.</b>	<b>Sewing equipment</b> . . . . .	<b>7</b>
<b>5.</b>	<b>Optional equipment</b> . . . . .	<b>9</b>
<b>6.</b>	<b>Technical parameters</b> . . . . .	<b>11</b>
<b>7.</b>	<b>Machine operation</b>	
7.1	Needle threading . . . . .	12
7.2	Hook thread winding . . . . .	13
7.3	Bobbin fixing and hook threading . . . . .	14
7.4	Thread tension adjustment . . . . .	15
7.4.1	Hook thread tension adjustment . . . . .	15
7.4.2	Needle thread tension adjustment . . . . .	16
7.5	Needle replacement . . . . .	17
7.6	Foot lifting . . . . .	18
7.7	Foot pressure setting . . . . .	19
7.8	Stitch length setting . . . . .	19
7.9	Backtacking (reverse feeding; closing up) . . . . .	20
7.10	Zig-zag stitch width (throw) and position setting . . . . .	21
7.11	Starting up of manually controlled machine with clutch motor . . . . .	22
7.12	Control of machine equipped with clutch positioning motor and solenoid automatic control . . . . .	23
7.12.1	Control pedal . . . . .	23
7.12.2	Key control panel . . . . .	24
<b>8.</b>	<b>Efka DC1550/DA321G positioning motor</b> . . . . .	<b>25</b>
<b>9.</b>	<b>Sewing with machine equipped with positioning motor</b>	
9.1	Machine automatic functions . . . . .	26
9.2	Example of machine control/operation . . . . .	27
<b>10.</b>	<b>Maintenance</b>	
10.1	Cleaning and checking . . . . .	28
10.2	Lubrication . . . . .	29

For your notes:

## 1. Machine description

- A flatbed single-needle machine.
- It sews a double-thread zig-zag lockstitch.
- It has a bi-directional drop feed.
- The machine is equipped with a horizontal hook.
- Wick lubrication.
- There is an automatic bobbin winder on the machine arm.
- According to the selected class, the machine has a manual or automatic control by solenoid including thread trimming device.

## 2. Machine use

### **Subclass 523i**

Stitching of laces, ribbons, and tacking of ready-made ladies underwear and ladies clothes. The sewn material must not be thicker than 4 mm when pressed down under the presser foot.

### **Subclass 524i**

Stitching of undercollars in jacket neckholes. Stitching of top collars on the undercollar overhang. Stitching of lining collar in upper part of trousers. Seaming of edges and similar operations in ready-made overgarment when sewing woolen, cotton, synthetic, and mix materials. The sewn material must not be thicker than 4 mm when pressed down under the presser foot.

### **Subclass 525i**

Ornamental(shape) stitching in ready-made overgarment and ladies underwear made of elastic materials. Ornamental stitching in textile footwear. The sewn material must not be thicker than 4 mm when pressed down under the presser foot.

### **Subclass 527i**

Shoe sewing: stitching of quarters and linings, topstitching of tongues, sewing of home slippers, ornamental stitching. Joining of leather and textile materials in leather industry. The sewn leather must not be thicker than 4 mm; the sewn textile must not be thicker than 8 mm when pressed down under the presser foot.

Dry material only can be sewn which must not contain hard objects because the machine is not equipped with an eye guard. This machine can be installed and operated in dry and maintained premises only. If the machine is used in premises which are not dry and maintained, further measures may be needed which are to be discussed (see EN 60204-31:1999).

As an industrial sewing machine producer we suppose that an at least instructed operator will work with the machine so that the operator can be expected to know all usual conditions or their risks.

### 3. Subclasses

Class and subclass	Needle number	Hook		Foot lifting		Thread trimming		Backtacking (closing)	
	1 needle	small (standard)	large	with knee lever	with solenoid	without thread trimmer	with thread trimmer	with hand lever	with solenoid
523i 411001	X	X		X		X		X	
523i 447001	X	X			X		X		X
524i 811001	X		X	X		X		X	
524i 847001	X		X		X		X		X
525i 811001	X		X	X		X		X	
525i 847001	X		X		X		X		X
527i 811001	X		X	X		X		X	
527i 847001	X		X		X		X		X

## 4. Sewing equipment

E-Nr. E-No.  Abb.-Nr. Fig.No.	Für Unterklasse / For Subclass  Verwendungszweck / Use	Materiál.-čís. /Material Nr.	Stehová deska Throat plate		Podavač Feed dog ④				Patka Foot ②		Vodič/Guide Jeheľník/ Needle holder Systém jehly -rozměr / Needle system /-size *					
			Rozměr jehelneho otvoru/Stitch hole size mm	Stehová deska/Throat plate ③	Zásuvná deska, levá/Slide, left	Zásuvná deska, pravá/Slide, right	Rozteč zubů/Tooth pitch mm	Pilové ozubení/Serrated mm	Pilové ozubení šikmé/Serrated, oblique mm	Křížové ozubení/Cross toothed mm		Oboustranné ozubení/Roof-shaped mm	Kloubová kompenzační/Compensating hinged	Kloubová s drážkou zepředu/ Hinged with front thread slit	Kloubová s drážkou pro nit z boku/ Hinged with side thread slit	Kolečková patka/Roller/presser
523 E 069	523i 411001; 523i 447001 Sewing equipment, 3-lined feed dog, needle size Nm 80-110, stitch length max. 5 mm, throw width max. 6 mm, for light and medium weight material.	S791 124069 35	7,8 x 1,5	S080 811636			1,0	S080 651330				S980 031649				134/100
523 E 070	523i 411001; 523i 447001 Sewing equipment, 4-lined feed dog, needle size Nm 80-110, stitch length max. 5 mm, throw width max. 6 mm, for light and medium weight material.	S791 124070 35	7,8 x 1,5	S080 811701			1,8	S080 651473		S980 031586						134/100
525 E 032	524i 811001; 524i 847001 525i 811001; 525i 847001 Sewing equipment, 4-lined feed dog, needle size Nm 80-110, stitch length max. 5 mm, throw width max. 10 mm, for light and medium weight material.	S791 124032 35	11,6 x 1,2	S080 811641			1,0	S080 651504				S980 031603				134/80
525 E 033	524i 811001; 524i 847001 525i 811001; 525i 847001 Sewing equipment, 3-lined feed dog, needle size Nm 80-110, stitch length max. 5 mm, throw width max. 10 mm, for light and medium weight material.	S791 124033 35	11,8 x 1,5	S080 811637			1,8	S080 651336				S980 031603				134/110
525 E 075	524i 811001; 524i 847001 525i 811001; 525i 847001 Sewing equipment, 4-lined feed dog, needle size Nm 80-110, stitch length max. 5 mm, throw width max. 10 mm, for medium weight material.	S791 224075 35	11,6 x 1,5	S080 811699			1,5	S080 651472				S980 031603				134/110
527 E 023	525i 811001; 525i 847001 527i 811001; 527i 847001 Sewing equipment for sewing butt seams, 3-lined feed dog, needle size Nm 110-130, stitch length max. 5 mm, throw width max. 10 mm, for medium heavy weight material.	S791 400023	11,8 x 1,7	S980 022282			1,8	S080 651428				S980 031603				134; 134-35/110
527 E 048	527i 811001; 527i 847001 Sewing equipment for two needle cordin seams with or without filler cord, 3-lined feed dog, needle size Nm 120-160, stitch length max. 5 mm, needle gauge 7 mm, for medium and heavy weight material.	S791 430048 35	9 x 2,5	S980 022840			1,8	S080 651499				S980 022839				134-35/130

Note: Sewing equipment is illustrated in the spare parts list.

\* Needles are not supplied.

E-Nr. E-No. Abb.-Nr. Fig.No.	Šicí vybavení  Für Unterklasse / For Subclass  Verwendungszweck / Use	Materiál-čís. /Material Nr.	Stehová deska Throat plate				Podavač Feed dog ④				Patka Foot ②						
			Rozměr jehelního otvoru/Stitch hole size mm	Stehová deska/Throat plate	Zásuvná deska, levá/Slide, left	Zásuvná deska, pravá/Slide, right	Rozteč zubů/Tooth pitch mm	Pilové ozubení/Serrated mm	Pilové ozubení šikmé/Serrated, oblique mm	Křížové ozubení/Cross toothed mm	Oboustranné ozubení/Roof-shaped mm	Kloubová kompenzační/Compensating hinged	Kloubová s drážkou zepředu/ Hinged with front thread slit	Kloubová s drážkou pro nit z boku/ Hinged with side thread slit	Kolečková patka/Roller presser	Vodíč/Guide	Jehelník/ Needle holder
527 E 060	527i 811001; 527i 847001 Sewing equipment for two needle cordin seams with or without filler cord, 3-lined feed dog, needle size Nm 110-130, stitch length max. 5 mm, needle gauge 4 mm, for medium heavy weight material.	S791 430060 35	6 x 2,1	S980 022867			1,8						S980 022839				134-35/110
527 E 061	527i 811001; 527i 847001 Sewing equipment for two needle cordin seams with or without filler cord, 3-lined feed dog, needle size Nm 110-130, stitch length max. 5 mm, needle gauge 5 mm, for medium heavy weight material.	S791 430061 35	7 x 2,3	S980 022868			1,8						S980 022839				134-35/110
527 E 461	527i 811001; 527i 847001 Sewing equipment, 3-lined feed dog, needle size Nm 100-130, stitch length max. 5 mm, throw width max. 10 mm, for light weight material.	S791 124061 35	11,8 x 1,8	S080 811634			1,8					S980 031603					134-35/110
528 E 027	527i 811001; 527i 847001 Sewing equipment, 3-lined feed dog, needle size Nm 110-130, stitch length max. 5 mm, throw width max. 10 mm, for medium weight material.	S791 124027 35	11,8 x 1,8	S080 811557			1,8					S980 031602					134-35/120
525 E 028	527i 811001; 527i 847001 Sewing equipment, 3-lined feed dog, needle size Nm 120-160, stitch length max. 5 mm, throw width max. 10 mm, for heavy weight material.	S791 124028 35	12,2 x 2,2	S080 811772			1,8					S980 031586			S080 271530		134-35/160







































Note: Sewing equipment is illustrated in the spare parts list.

\* Needles are not supplied.

## 5. Optional equipment

Order number	Optional equipment
S359 600030	Complete motor FIR 1148/552/3
S359 600057	Complete motor EFKA DC1550/DA321G
9800 330009	Control panel V810 (for EFKA motor)
9800 330010	Control panel V820 (for EFKA motor)
S080 836491	Control panel V810 or V820 bracket
S072 500100	Complete stand (including stand table top)
S615 000316	Table top (separate)
S981 069440	Knee lever for mechanical foot lifting
S794 222012	Lighting lamp Z 012
S980 035456	Gauge for class 52X
S980 000293	Unwinding device A-M 293
S980 000294	Unwinding device A-M 294
S980 000312	Edge hemming set A-M 312
S980 031586	Complete foot ZZ 6MM
S980 031652	Complete foot ZZ 10MM
S080 811768	Throat plate (for soft material sewing)
S791 235002	Unwinding device
S791 630003	Double needle sewing equipment
S980 008253	Hook R 253
S794 222013	Sewing lamp diode Z 013

## Cams for shape sewing for subclass 525i

Commercial Marking	Order number	Quantity sewing points/ 1 cam turn	Quantity sewing points/pattern	Pattern width	Single-needle		Double-needle	
			Stitch length		Max. machine speed st/min	Pattern	Max. machine speed st/min	Pattern
525 Z 037	S080 674219	12		-	4400		3800	
525 Z 038	S080 674113	12	4 1-3	4,5 - 10	3800		3400	
525 Z 039	S080 674114	12	12 1-3	4,5 - 10	3800		3400	
525 Z 040	S080 674115	12	6 1,5-3	3,5 - 6	3800		3400	
525 Z 041	S080 674116	12	12 1,5-5	4,5 - 10	3800		3800	
525 Z 042	S080 674117	12	3 1,5-4	3,5 - 6	3800		3400	
525 Z 043	S080 674118	12	4 1-3	4 - 6	3800		3400	
525 Z 044	S080 674119	12	6 1-3	4 - 10	3800		3400	
525 Z 045	S080 674120	12	12 1,5-3	2 - 5	3800		3400	
525 Z 046	S080 674121	12	12 1,5-3	2 - 5	3800		3400	
525 Z 047	S080 674122	12	2 1-3	3,5 - 6	3800		3400	
525 Z 048	S080 674123	12	12 1-3	4,5 - 10	3800		3400	
525 Z 049	S080 674124	12	6 1-3	4,5 - 10	4400		3800	
525 Z 050	S080 674125	12	4 1-3	2 - 6	3800		3400	
525 Z 051	S080 674221	12	6 1,5-3	3,5 - 6	3800		3400	
525 Z 052	S080 674226	12	2 1-3	2 - 4,5	3800		3400	
525 Z 053	S080 674227	12	2 1-3	1 - 2,4	3800		3400	
525 Z 054	S080 674228	12	2 1-3	1,5 - 4	3800		3400	
525 Z 055	S080 674229	12	3 1,5-4	3,5 - 6	3800		3400	

## 6. Technical parameters

	Class and subclass			
	523i 411001 523i 447001	524i 811001 524i 847001	525i 811001 525i 847001	527i 811001 527i 847001
Zig-zag stitch max. width/mm	6	10	10	10
Maximum sewing speed for stitch length 6 mm	5000	4400	according to cams used	3400
Maximum sewing speed for stitch length 8 mm	-	4000	according to cams used	2500
Maximum sewing speed for stitch length 10 mm	-	3500	according to cams used	2000
Standard sewing speed *	3500	3500	3500	2000
Needle system	134	134	134	134-35; 134-35 LR

\* The machine is set up to the standard sewing speed in the factory.

Stitch type	double thread zig-zag lockstitch
Stitch length	max. 5.5 mm
Foot lifting with hand lever	5 mm
Foot lifting with knee lever or solenoid	12 mm
Needle number	see table of sewing equipment
Manually controlled subclass	clutch motor 2800 rpm.
Solenoid-controlled subclass reverse run after thread trimming	DC motor (AC servo)-positioning motor with
Sewing head weight	40 kg
FIR motor weight	18 kg
Efka DC1550 motor weight	10 kg
Stand weight	30 kg
Thread length after trimming	max. 20 mm
Machine head clear workspace	265 x 120 mm
Machine table dimensions	178 x 476 mm
Input of machine with clutch motor	max. 700 kW (short-time at start up)
Input of machine with DC motor	max. 800 kW (short-time at start up)
Machine floor plan dimensions (including stand)	1060 x 550 mm
Machine height (including yarn stand)	1490 mm
Acoustic pressure equivalent level of a separate machine at workplace at 20 % machine utilization under standard sewing conditions in a shift	83 dB/A

GB

## 7. Machine operation

### 7.1 Needle threading

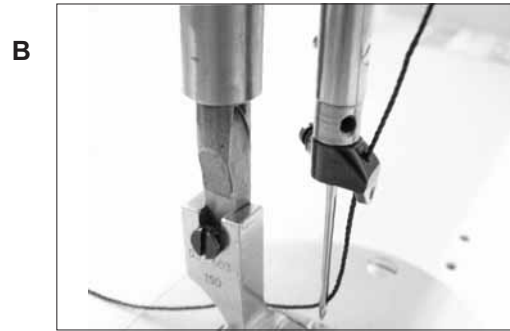
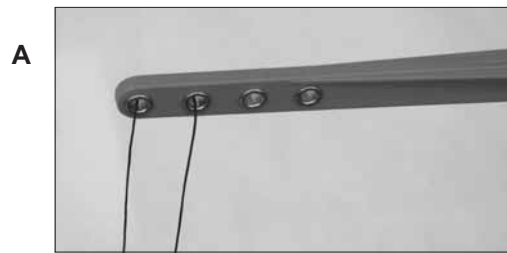

#### **Attention! Danger of injury!**

Thread when the main switch is switched off and motor stopped!

- Do the threading according to picture (A) and detail (B).
- When trimming the material edges, do the threading according to picture (A) and detail(C).

## 7.2 Hook thread winding

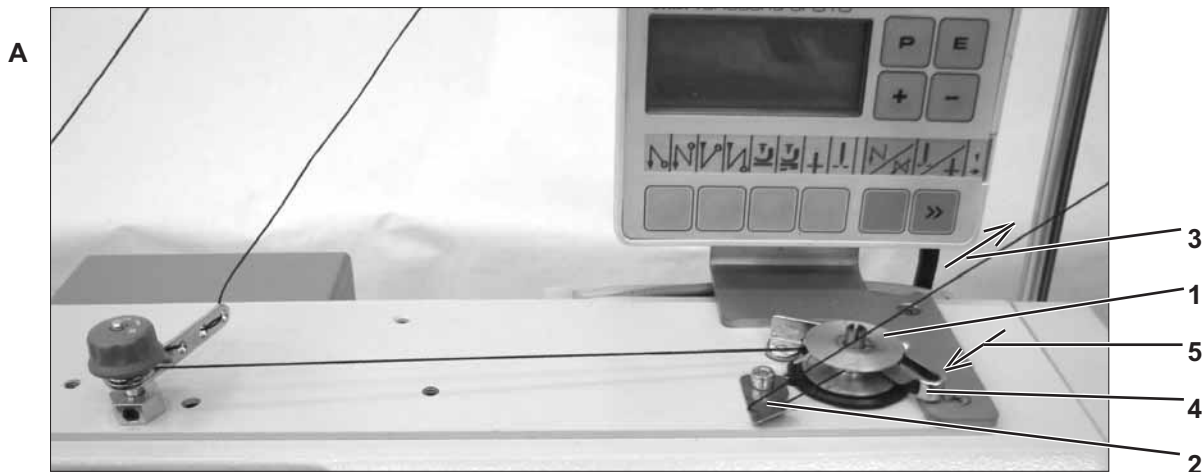
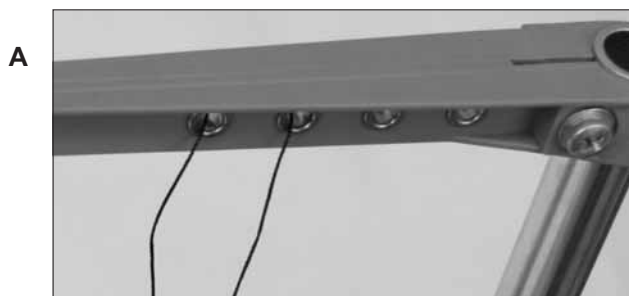

- Fix the bobbin (1) on the winder.
- Do the threading according to picture (A), wind 5 times round the bobbin.
- Insert the thread under cutter (2) and tear off by pulling in the arrow direction (3).
- Pull the lever (4) in the arrow direction (5).
- Start the machine up.
- After the bobbin winding, wind the thread round the cutter (2) according to picture (B) and tear it off by pulling in the arrow direction (3).
- Fix another bobbin immediately and prepare its winding during the sewing.

### 7.3 Bobbin fixing and hook threading

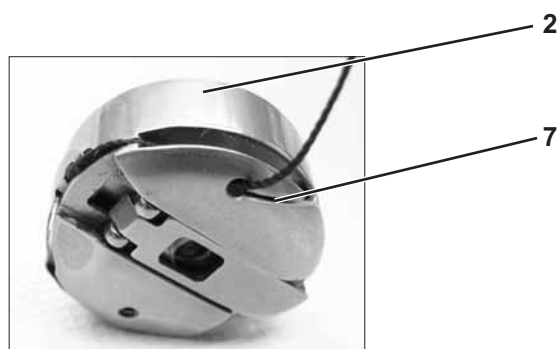
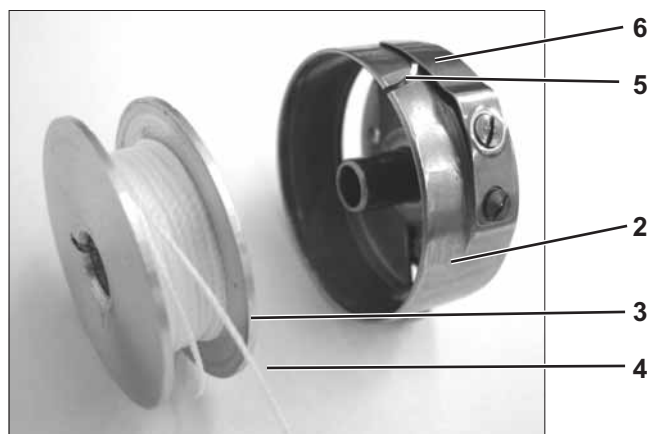
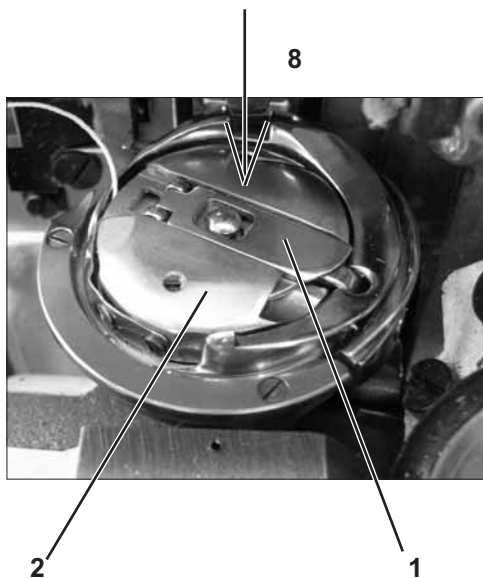

#### **Attention! Danger of injury!**

Switch the main switch off and wait for the motor stopping.

- Tilt the flap (1), grip it and pull the bobbin case (2) out of the hook.
- Put the bobbin (3) in the bobbin case with the thread end (4) oriented according to the picture (2).
- Draw the thread end (4) through the slit (5), pull under the spring (6) and pull into the slit (7).
- Insert the case (2) back in the hook and press it down in the arrow direction (8) till the lock inside the case clicks and secures it against falling out.
- Make one stitch without the sewn material, and drawing the thread upper end, pull the hook thread end outwards above the throat plate.

## 7.4 Thread tension adjustment

### 7.4.1 Needle thread tension adjustment

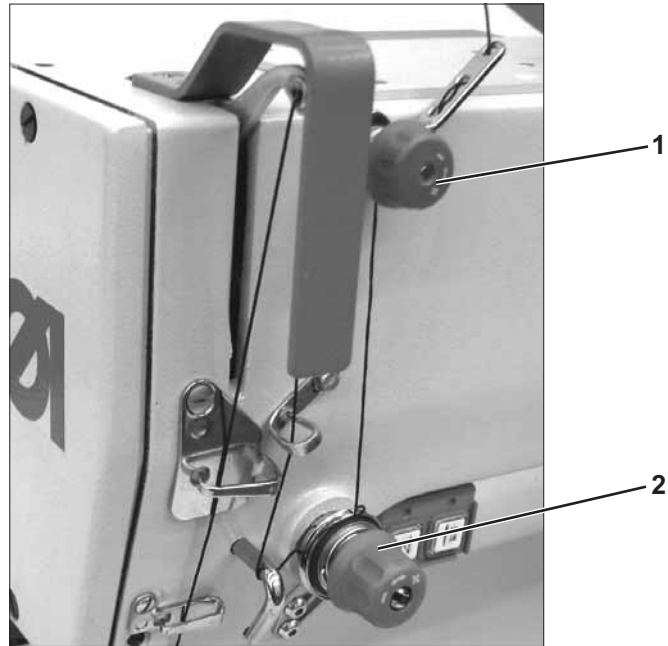

#### Secondary tensioner adjustment (1)

- Adjust the secondary tensioner (1) so that it has as small tension as possible, but high enough so as the thread cannot be pulled out from the tensioner (1) at the material removing after previous trimming (when the tensioner (2) is opened - switched off). (The tensioner (1) is never switched off).

#### Main tensioner adjustment (2)

- Regulate the thread tension with the tensioner (2) until you achieve a good interlacing of the threads (see below).

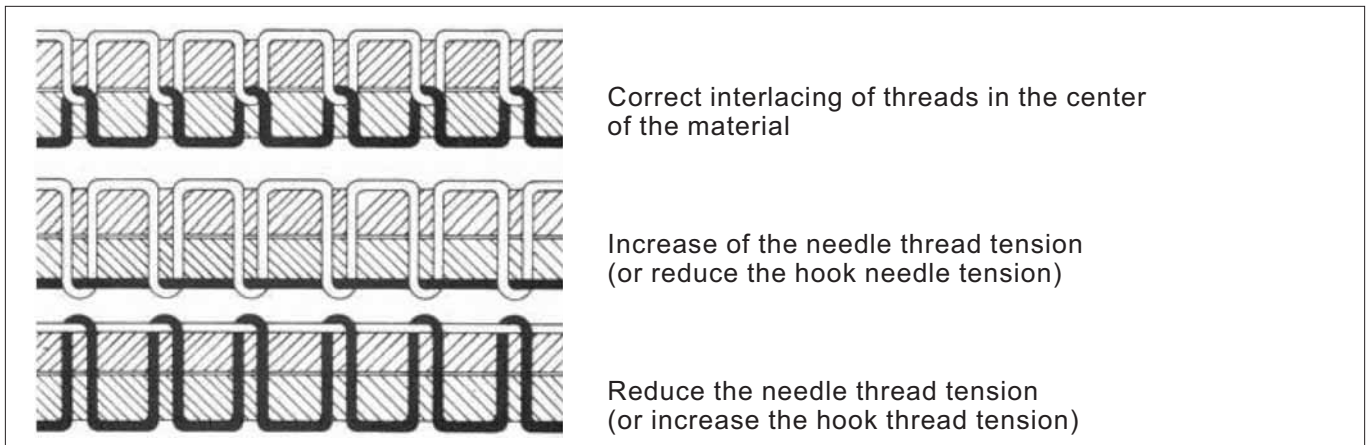

GB

## 7.4.2 Hook thread tension adjustment

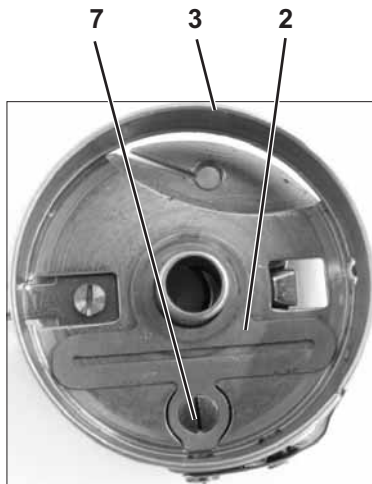

A



B

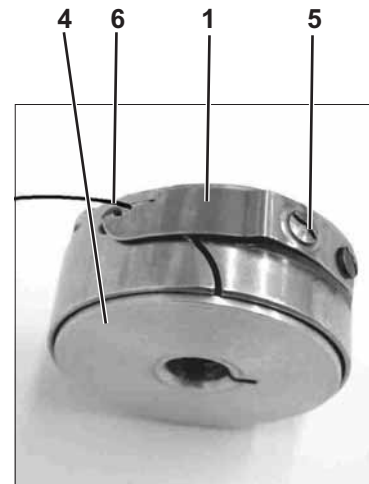

C



### Attention! Danger of injury!

Do adjustments when the main switch is switched off and motor stopped!

- The hook thread tension depends on the adjustment of springs (1) and (2).

#### Tension spring (1) adjustment

- Remove the bobbin case (3) from the machine and insert a full-wound bobbin (4).
- Do a complete threading according to picture (B).
- Regulate the spring (1) pressure with a screw (5) so that the thread tension is in balance with the case and bobbin weight - when hung down on the thread end (6), the case is dropping slowly with its own weight.

#### Adjustment of bobbin brake spring at the thread trimming (2)

- Bobbin braking should be as small as possible because it causes difference of tensions of full and empty bobbin and subsequently of thread interlacing in the stitch (defective look of the seam).
- Regulate the bobbin braking with a screw (7) and watch the bobbin unwinding after the thread trimming: remove the case (3) from the machine, grip it so that the bobbin cannot turn and pull out the thread end (8). At a correct adjustment, approx. 10 mm of thread will be pulled out of the case.

## 7.5 Needle replacement

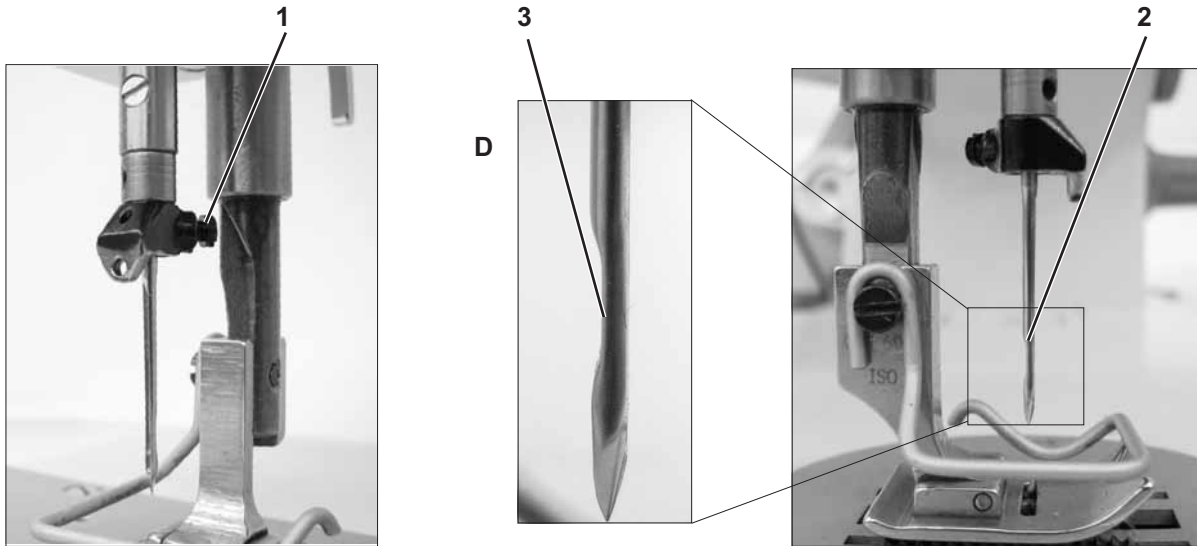

### **Attention! Danger of injury!**

Do the needle replacement when the main switch is switched off and motor stopped.

GB

- Loosen the screw (1) and remove the needle (2).
- Fix a new needle and turn it so that the needle scarf (3) is oriented according to detail (D).
- Tighten the screw (1).

## 7.6 Foot lifting

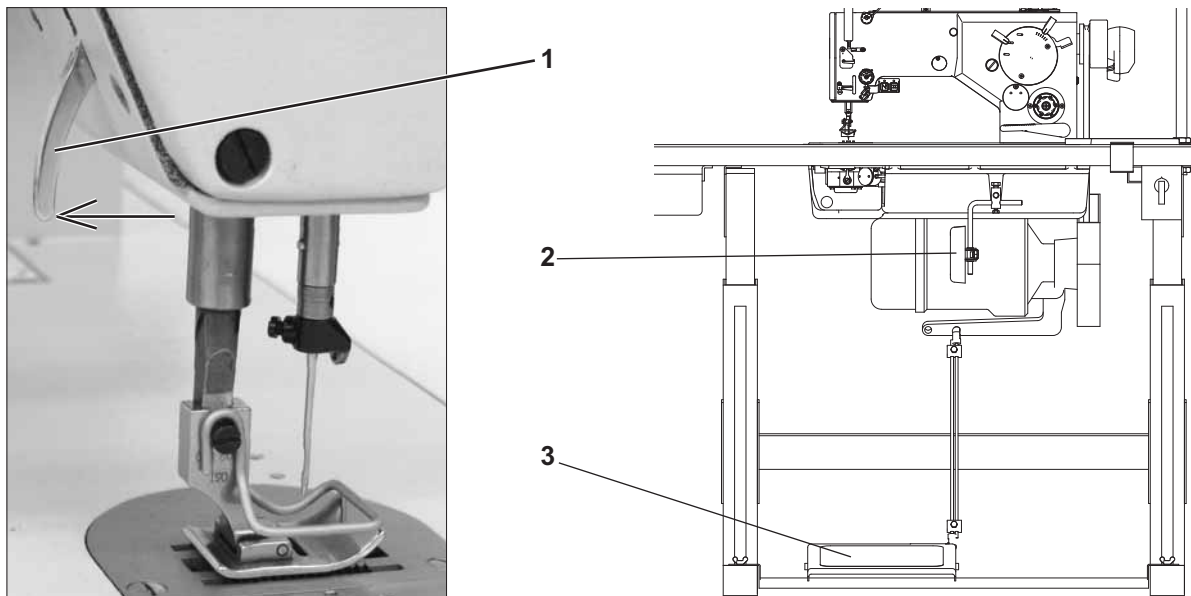

### Foot lifting with a hand lever

- Lift the foot by pressing the lever (1) to a stop (foot remains lifted).
- Lower the foot by returning the lever (1) to initial position or by pressing the knee lever (2) /if there is any/ and by its subsequent releasing or by the automatic foot lifting by means of the pedal and subsequent pedal releasing.
- After the foot lifting by hand lever, the machine may be started up (e. g. when winding the hook thread).

### Foot lifting with a knee lever (if there is any)

- The foot is lifted by pressing the lever (2); the foot is lowered by releasing the lever.

### Automatic foot lifting - with solenoid - with pedal

(applies to subclasses with the positioning motor and automatic control)

- Tread the pedal (3) in position -1 (see section 7.11). The foot is lifted.
- Automatic foot lifting after trimming can be pre-selected (see section 7.11). The foot is lowered by the pedal (3) treading in position +1.



### **Attention!**

At the foot lifting with the knee lever or automatically the machine must not run. There is a threat of destruction.

## 7.7 Foot pressure setting

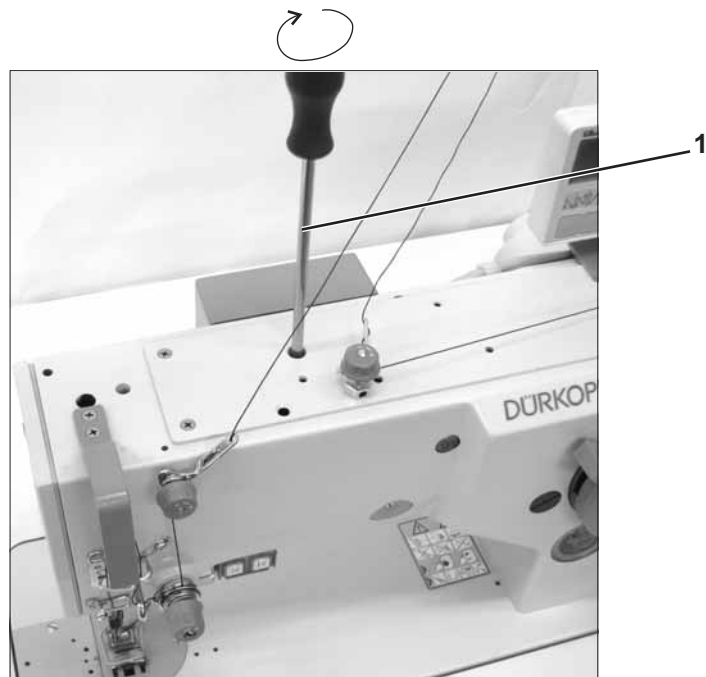

- Regulate the foot pressure by means of a screwdriver (1) which is supplied with the machine accessories.
- The pressure increases by turning in the arrow direction and vice versa.
- The foot pressure should be as small as possible, but strong enough so that the feeding is reliable even at a high sewing speed.
- 

GB

## 7.8 Stitch length setting

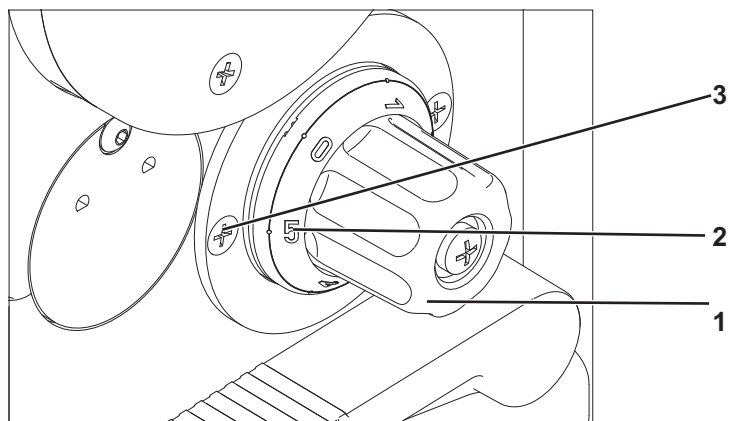

- Turn the knob (1) so that the number (2) indicating the required stitch length in mm is opposite the screw (3).

## 7.9 Backtacking (reverse feed; closing up)

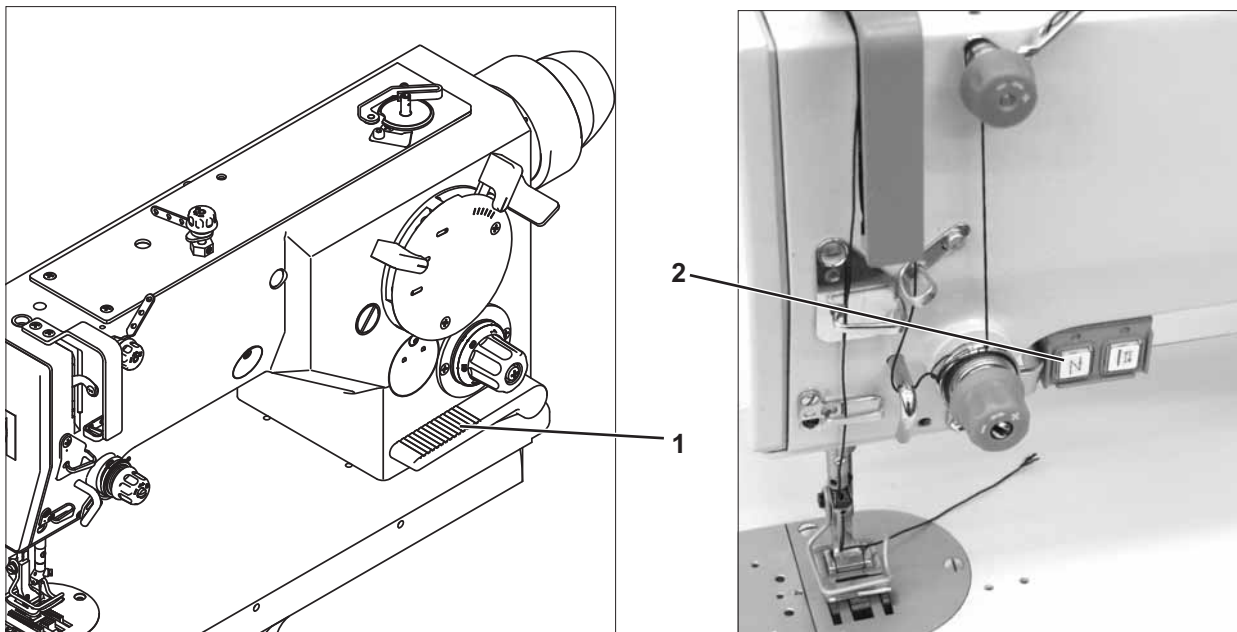

### Backtacking with a hand lever (applies to manually controlled subclasses)

- Press the lever (1) downwards. The machine will feed in the reverse direction until you release the lever.

### Backtacking with a microswitch (applies to automatically controlled subclasses)

- Press the microswitch (2). The machine will backtack until you release the grip.

### Automatic backtacking (bar sewing, bartacking)

On machines equipped with the positioning motor and automatic control the automatic backtacking can be pre-selected with a pre-selected number of reverse stitches both at the beginning and at the end of the seam. At the beginning of the seam (after previous thread trimming) after the pedal treading forwards the machine will sew the pre-selected bar and continue the sewing. At the end of the seam it will sew the pre-selected bar at the pedal treading in position -2 (see section 7.11).

## 7.10 Setting of zig-zag stitch width (throw) and position

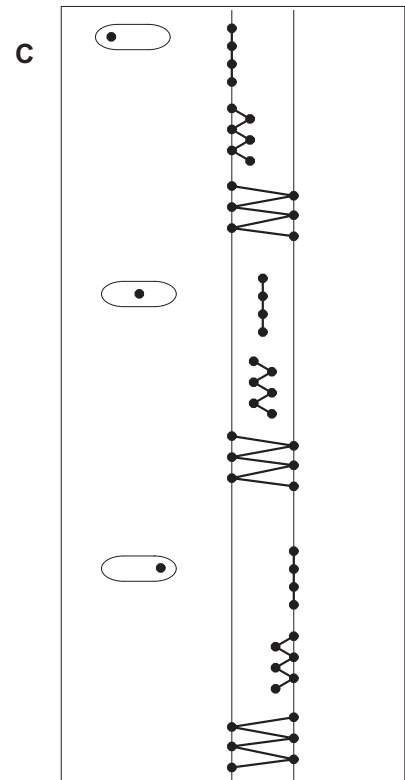
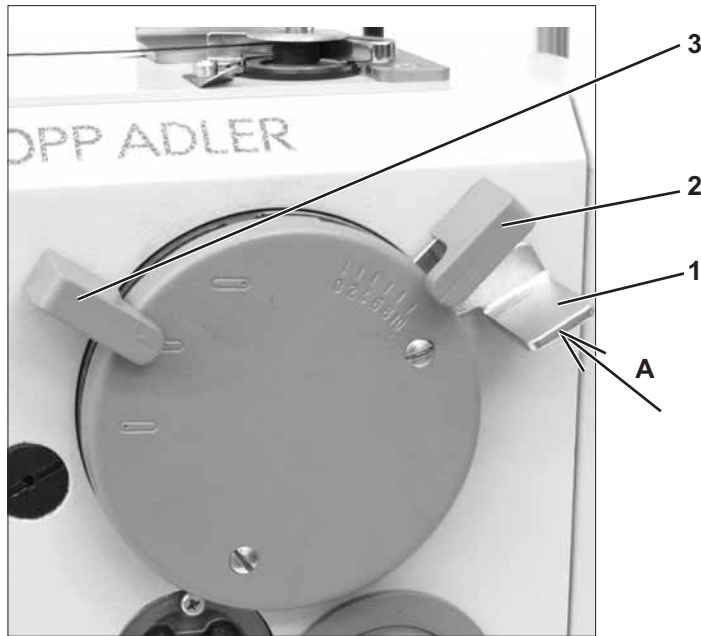

### Attention!

At setting the zig-zag stitch width (throw) and position the needle must not be inside the sewn material. There is a threat of the needle breaking!

#### Setting of zig-zag stitch width

- Press the lever (1) in the arrow direction (A) until it strikes the lever (2)  
– the lever arrest is released (2). Grip both levers at the same time and set the zig-zag stitch width by turning the lever (2) against the selected number indicating the stitch width.
- Arrest the lever (2) position by turning the lever (1) against the arrow direction (A).

#### Setting of zig-zag stitch position

- Press the lever (1) in the arrow direction (A) until it strikes the lever (2)- the lever arrest is released (3). Make sure that the lever setting does not change at the arrest switching off (2).
- Press the lever (3) and turn it at the same time up to the stop (inside the machine) against the respective symbol indicating the zig-zag stitch position. Only the middle position of the lever is arrested with a lock.
- After the lever (3) setting, carry out arresting with the lever (1).
- In picture (C) there are examples of setting the zig-zag stitch width and position from which it is visible that the zig-zag stitch width does not change at the position change.

## 7.11 Starting up of manually controlled machine with clutch motor

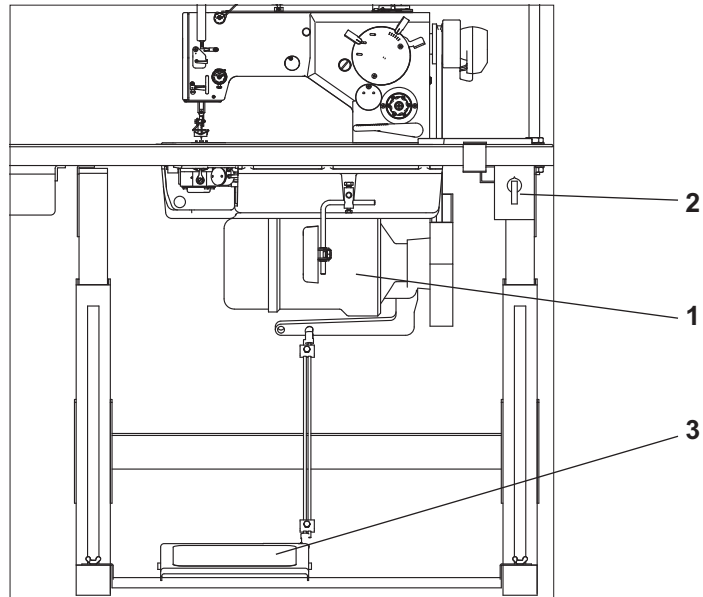

- Start up the motor (1) with the switch (2) - the drive motor is running continuously.
- Tread the pedal (3). The drive friction clutch switches in this way and the sewing machine starts running.
- Regulate the sewing speed by pressure on the pedal (3). The friction clutch slip changes and thus also the machine speed changes in dependency on the pressure.
- Release the pedal(3). The sewing machine will stop.

## 7.12 Control of machine equipped with positioning motor and solenoid automatic control

### 7.12.1 Control pedal

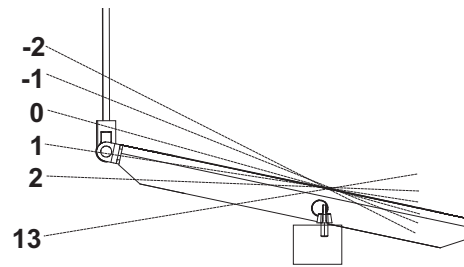

The pedal position is scanned with a proximity switch which distinguishes 16 levels.

The meaning is in the table:

Pedal position	Pedal motion	Meaning
-2	Heel fully backwards	Command for thread trimming (seam finish)
-1	Heel slightly backwards	Command for foot lifting
0	Neutral position	See note
1	Slightly forwards	Command for foot lowering
2	Further forwards	Sewing at minimum speed (1gear)
3	Further forwards	Sewing - 2 speed gear
:	:	:
13	Fully forwards	Sewing at maximum speed (12 gear)

Note: The needle position can be pre-selected for the neutral position (needle down/up) as well as for the foot position (down/up) at the seam-stop (by putting the pedal in the neutral position), and for the foot position (down/up) after the seam finishing (by treading the pedal with heel fully backwards and putting the pedal in the neutral position).

## 7.12.2 Key control panel



Key	Function
1	<b>Hand backtacking</b> When the key is pressed at sewing, the sewn material is fed backwards.
2	<b>Needle positioning in upper or bottom position</b> By the parameter <b>F-242</b> (DA321) the key function can be defined: 1 = needle up/down 2 = needle up 3 = one stitch (factory setting is 1)

## 8. Efka DC1550/DA321G positioning motor

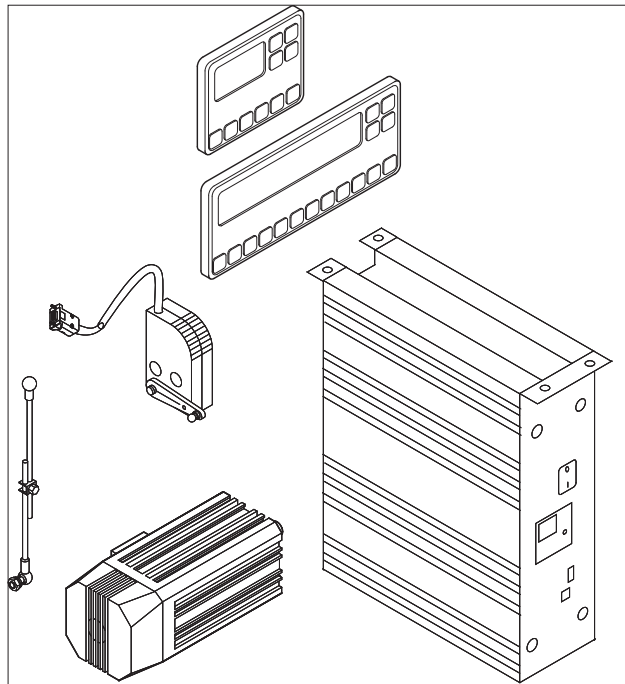

GB

DA321G control contains all needed control elements for a function switchover and parameter setting. The operation is possible without the control panel, the sewing programming is not enabled.

To the machine control also control panels V810 and V820 can be connected which are available as an attachment. By means of V820 control panel it is possible to program the sewing.

A detailed description of the control is included in the Instruction for Use supplied with the machine by the "EFKA DC1550 DA321G drive manufacturer (see also [www.efka.net](http://www.efka.net)).

## 9. Sewing with machine equipped with positioning motor

### 9.1 Machine automatic functions

The machine has functions stated below which are automatically carried out during the seam sewing dependent on:

- pre-selection
- pedal position (according to the machine operator s selection)
- work phase of seam sewing

<b>Automatic function</b>	<b>Pre-selection</b>
Needle positioning	<ul style="list-style-type: none"><li>• needle down at machine seam-stop</li><li>• needle up at machine seam-stop</li></ul> Note: After the seam finishing* the machine always stops with the needle up.
Bars	<ul style="list-style-type: none"><li>• standard</li><li>• ornamental**</li></ul>
Initial bar	<ul style="list-style-type: none"><li>• single</li><li>• double</li><li>• standard bar stitch number forwards</li><li>• ornamental bar stitch number forwards</li><li>• standard bar stitch number backwards</li><li>• ornamental bar stitch number backwards</li></ul>
End bar	<ul style="list-style-type: none"><li>• single</li><li>• double</li><li>• standard bar stitch number backwards</li><li>• ornamental bar stitch number backwards</li><li>• standard bar stitch number forwards</li><li>• ornamental bar stitch number forwards</li></ul>
Thread trimming	<ul style="list-style-type: none"><li>• on</li><li>• off</li></ul>
Automatic foot lifting	<ul style="list-style-type: none"><li>• foot lowered at seam-stop</li><li>• foot lifted at seam-stop</li></ul>

\* The seam is finished after the pedal transition to position -2 (if the thread trimming is pre-selected, then after trimming).

\*\* At the bar sewing, the ornamental bar is characterized by the needle sticking in the same points as in the previous seam. On the sewing direction change the machine will stop for a moment.

The automatic function pre-selections are described in the drive manufacturer's accompanying Instruction for Use.

For Efka DA321G motor also see the drive manufacturer's Instruction for Use on website [www.efka.net](http://www.efka.net). Certain automatic functions can be pre-selected by means of keys. Their description is included in the publication Efka Instructions for Use, sections 4, 12, 13.

Further automatic functions can be pre-selected through the drive parameter change. Every such function has its parameter number. For the parameter number also the parameter value can be pre-selected.

The parameter change is described in the publication Efka Instructions for Use, sections 4.2, 4.3.

List of operator level parameters is included in the publication Efka Parameter List, section 5.1.

## 9.2 Example of machine control at sewing

### Pedvolba:

- needle down at machine seam-stop
- standard bars
- initial double bar
- end double bar
- thread trimming on
- foot lowered at seam-stop
- foot lifted at seam finishing

Operator's operation	Machine work
	Machine is at standstill. Needle is in upper position. Foot is lifted in accordance with pre-selection.
Sewn material inserting.	
Pedal treading to position +1.	Foot lowering.
Pedal releasing to position 0.	Foot lifting.
Material position correcting.	
Pedal treading to position +1.	Foot lowering.
Pedal treading to position +3.	Sewing of standard double bar (at the speed which was pre-selected by the manufacturer) and subsequent sewing at the speed corresponding with speed gear +3.
Pedal releasing to position 0.	Machine stopping with needle down.
Pedal treading to position -1.	Foot lifting.
Material turning on needle.	
Pedal treading to position +5.	Foot lowering and subsequent machine start up at the speed of 5th sewing speed gear.
Pedal treading to position -2.	Speed reducing. Sewing of standard double bar. Thread trimming under throat plate and machine stop with needle up. Foot lifting.
Pedal releasing.	(Foot will remain lifted).
Sewn material removing.	

# 10. Maintenance

## 10.1 Cleaning and checking



### Attention! Danger of injury!

Maintenance may be carried out only when the machine is switched off and the motor stopped!



### Attention!

Maintenance must be carried out in prescribed intervals. Neglect of maintenance may result in malfunction requiring costly repair.

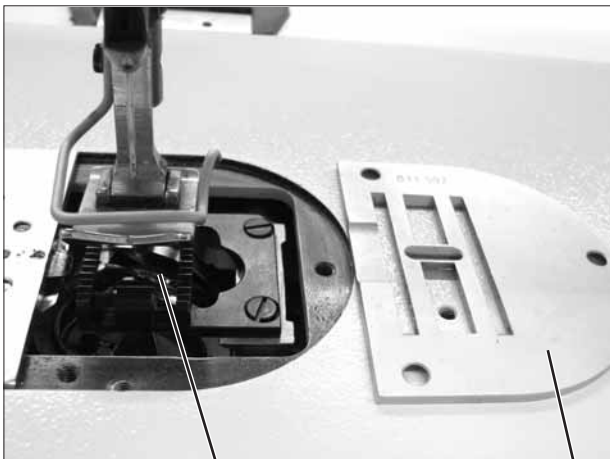

3

1

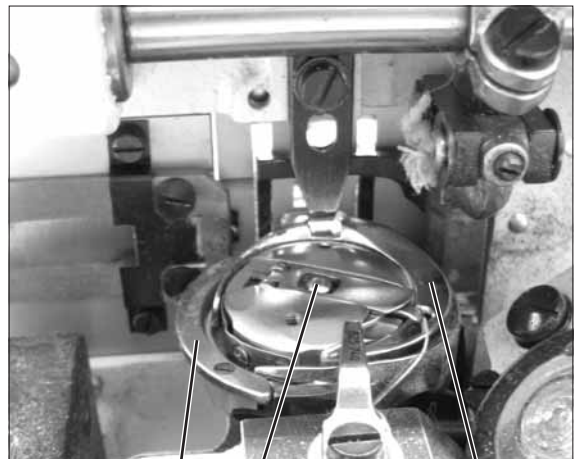

5

2

4

### Maintenance operation

### Maintenance interval

Throat plate (1) disassembly. Cleaning of throat plate, hook(2), feed dog (3) and their surroundings. It is possible to clean with compressed air. Re-lubrication of hook path with oil and washing of dirt out of the path. 1 week  
Spraying the unnecessary oil out of the hook at the machine high speed operation.  
Check of oil reserve in oil tanks (see section 10.2).

Cleaning of mechanisms in the base plate. Cleaning (vacuuming, wiping out) oil tray. Cleaning of ventilator grid on the motor.

1 month

Check of bobbin case (4) fitting clearance in the hook housing (5).  
Check of drive V-belt tension (checking method is described in the second part of this Instruction for Use). Lubrication of swinging shafts with grease (see section 10.2).

1 year

## 10.2 Lubrication



### Attention! Danger of injury!

Oil may cause dermatic diseases. Avoid complexion staining with oil. In case of staining wash the affected spot in water with soap.



### Attention!

Handling of mineral oils is subject of legal prescriptions. Deposit the debased oil in an authorized dangerous waste scrap-yard! Protect the environment. Prevent oil leakages.

For this sewing machine lubrication use solely the lubrication oil **DA-10** or oil of the same properties with the following specification:

- viscosity at 40C      10 mm<sup>2/s</sup>
- inflammation point    150C

The oil **DA-10** is supplied by the company **DRKOPP ADLER AG** in different packings:

Volume	Order number
250 ml	9047 000011
1 l	9047 000012
2 l	9047 000013
5 l	9047 000014

To lubricate feed shafts use grease **Mogul LV2EP** which is supplied in 1 kg packing under **order number S111 200000**.



1 2

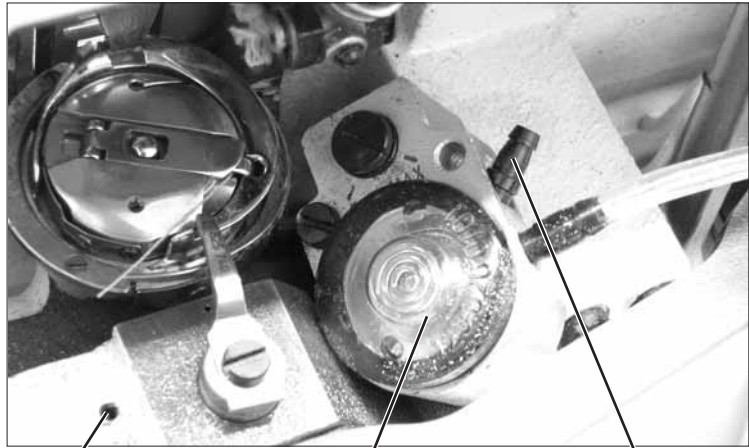

6 3 5

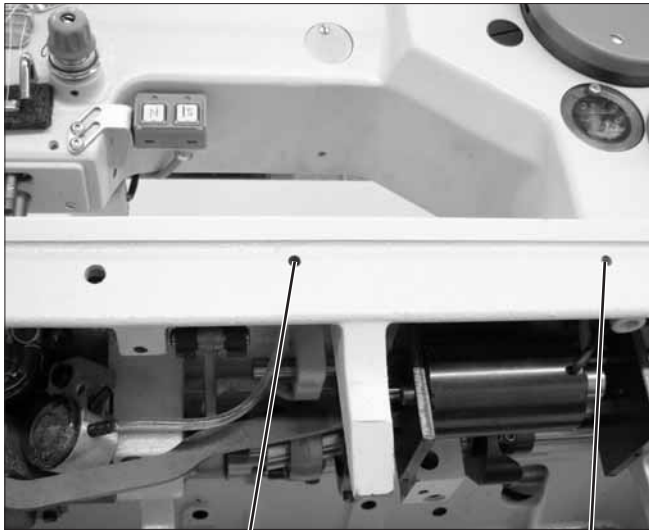

4 7

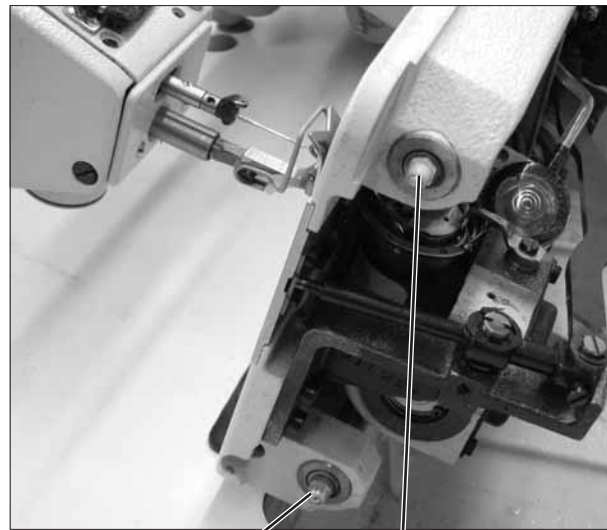

8 9

#### Oil lubrication

- If the oil volume in the tank (1) drops to the level indicated with MIN mark, add oil through the hole (2) up to MAX mark.
- Add oil into tank (3) through the hole (4) at least once a week until the oil starts flowing from the terminal(5).
- Add several drops of oil in holes (6) and (7) once a month.

#### Grease lubrication

- Add grease in grease cups(8) and (9) by means of a lubrication press once a year.