



# Instruction manual

# 524

# Contents - part A - Instruction manual:

1. Proper use of the machine .....	1
2. Description of the machine .....	1
3. Machine subclasses .....	1
4. Survey of equipment .....	1
<b>4.1 -for the subclass -101</b> .....	1
4.1.1 Necessary equipment .....	1
4.1.2 Sewing equipment.....	1
4.1.3 Optional equipment.....	2
<b>4.2 -for the subclass -105</b> .....	2
4.2.1 Necessary equipment .....	2
4.2.2 Sewing equipment.....	2
4.2.3 Optional equipment.....	2
5. Technical data .....	2
6. Operation of the machine .....	3
<b>6.1 Upper thread threading</b> .....	3
<b>6.2 Winding of thread on the hook bobbin</b> .....	3
<b>6.3 Needle insertion</b> .....	3
<b>6.4 Adjustment of the upper thread tension</b> .....	4
<b>6.5 Change of the hook bobbin, threading and setting of the bottom thread tension</b> .....	4
<b>6.6 Adjustment of the stitch length, reverse stitching</b> .....	5
<b>6.7 Adjustment of the zigzag stitch width and position</b> .....	5
<b>6.8 Regulation of the presser foot pressure, presser foot lifting</b> .....	5
7. Machine maintenance .....	6
<b>7.1 Cleaning</b> .....	6
<b>7.2 Lubrication</b> .....	6
8. Electronic control of the machine .....	7
<b>8.1 Control of sewing by means of control elements</b> .....	7
8.1.1 Via treadle .....	7
8.1.2 Via pushbutton.....	7
8.1.3 Via control panel Efka V 810/V 820 .....	7
<b>8.2 Adjustment of automatic functions via control panel for stop motor</b> .....	8
8.2.1 By using stop motor Efka with panel V 810 .....	8
8.2.1.1 Adjustment by means of buttons with fixed setting function .....	8
8.2.1.2 Setting by means of parameters.....	9
8.2.2 By using stop motor Efka with panel V 820 .....	10
8.2.2.1 Adjustment by means of buttons with fixed setting function .....	11
8.2.2.2 Setting by means of parameters.....	11
Operating instructions for eventual trouble shooting .....	13

## Foreword

This instruction manual is intended to help the user to become familiar with the machine and take advantage of its application possibilities in accordance with the recommendations.

The instruction manual contains important information on how to operate the machine securely, properly and economically. Observation of the instructions eliminates danger, reduces costs for repair and down-times, and increases the reliability and life of the machine.

The instruction manual is intended to complement existing national accident prevention and environment protection regulations.

The instruction manual must always be available at the machine/sewing unit.

The instruction manual must be read and applied by any person that is authorized to work on the machine/sewing unit. This means:

- Operation, including equipping, troubleshooting during the work cycle, removing of fabric waste
- Service (maintenance, inspection, repair and/or)
- Transport.

The user also has to assure that only authorized personnel work on the machine.

The user is obliged to check the machine at least once per shift for apparent damages and to immediately report any changes (including the performance in service), which impair the safety.

The user company must ensure that the machine is only operated in perfect working order.

Never remove or disable any safety devices.

If safety devices need to be removed for equipping, repairing or maintaining, the safety devices must be remounted directly after completion of the maintenance and repair work.

Unauthorized modification of the machine rules out liability of the manufacturer for damage resulting from this.

Observe all safety and danger recommendations on the machine/unit! The yellow-and-black striped surfaces designate permanent danger areas, eg danger of squashing, cutting, shearing or collision.

Besides the recommendations in this instruction manual also observe the general safety and accident prevention regulations!

## General safety instructions

The non-observance of the following safety instructions can cause bodily injuries or damages to the machine.

1. The machine must only be commissioned of the instruction book and operated by persons with appropriate training.
2. Before putting into service also read the safety rules and instructions of the motor supplier.
3. The machine must be used only for the purpose intended. Use of the machine without the safety devices is not permitted. Observe all the relevant safety regulations.
4. When gauge parts are exchanged (e.g. needle, presser foot, needle plate, feed dog and bobbin) when tread-ing, when the workplace is left, and during service work, the machine must be disconnected from the mains by switching off the master switch or disconnecting the mains plug.
5. Daily servicing work must be carried out only by appropriately trained persons.
6. Repairs, conversion and special maintenance work must only be carried out by technicians or persons with appropriate training.
7. For service or repair work on pneumatic systems the machine must be disconnected from the compressed air supply system. Exceptions to this are only adjustments and functions checks made by appropriately trained technicians.
8. Work on the electrical equipment must be carried out only by electricians or appropriately trained persons.
9. Work on parts and systems under electric current is not permitted, except as specified in regulations DIN VDE 0105.
10. Conversion or changes to the machine must be authorized by us and made only in adherence to all safety regulations.
11. For repairs, only replacement parts approved by us must be used.
12. Commissioning of the sewing head is prohibited until such time as the entire sewing unit is found to comply with EC directives.

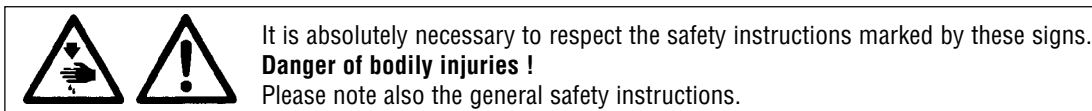

### **IMPORTANT WARNING!**

**To the feeding network cord, it is necessary to connect the respective network plug which has been approved in the country of utilizing the machine. This operation should be performed by a worker acquainted with the electric safety rules being in force in the given country. The supplier is not responsible for any damages caused by defective plug or owing to incorrect assembly of the plug.**

In spite of all safety measures made on the machines, inappropriate actions of the operator may lead to dangerous situations. In industrial sewing machines, attention should be paid to the following still remaining possible sources of injury:

1. Moving sewing needle
  - risk of injury when sewing with raised pressure foot or top roller, because the finger guard is then positioned too high.
2. Moving thread take-up lever
  - risk of injury when inadvertently or intentionally inserting the finger(s) between the thread take-up lever and its guard.
3. Moving pressure member
  - risk of injury when holding sewn work in immediate vicinity of the pressure member and beginning to insert under the pressure member a considerably thicker sewn work portion,
  - risk of injury when sinking the pressure member.
4. When switched off, the clutch motor slows down by inertia but would be reactivated by an accidental tread-ing down of the motor treadle. To avoid such risk, it is advised to hold the handwheel by hand and slightly to depress the motor treadle.

## Part A - Instruction manual

### 1. Proper use of the machine

The machine is destined for sewing on under collars into neck openings of jackets, for sewing on top collars on falls of under collars, for sewing on lining collars into the top parts of trousers, for sewing on pocket facings on trouser bags, for overedging of edges and similar operations in making-up outerwear, for sewing materials of wool, cotton and materials with admixture of synthetic fibres and woven fabrics of 100 % polyamide fibres. In general, only dry material may be sewn on these machines, which should not be thicker than 4 mm when being compressed by the presser foot. The material should not contain any hard objects, because in such opposite case the sewing operation would be possible only with an eye protector. Such eye protector is not supplied for the time being. When sewing very hard or compact materials with a thicker needle, the total thickness thereof is limited. In such case it is also necessary to reduce substantially the sewing speed below the value quoted in the par. 5. These machines may be installed and operated only in dry and maintained rooms.

As manufacturers of industrial sewing machines we start from the supposition that our machines will be operated at least by a trained staff, so that all usual operating activities and their eventual risks may be supposed to be known.

#### Machine noisiness

The noisiness of machines is measured according to ISO 3746, ISO 11204 at the maximum sewing speed.

**L<sub>aeq</sub>** = equivalent noise level of the machine itself on the working place converted in % of the machine utilization (dB) – is given in the following table

Type of the machine	Noisiness dB	% machine employment
524-101	83	20
524-105	83	20

### 2. Description of the machine

It is flat-bed single-needle machine. It sews with double-thread zigzag lock-stitch, with two-way drop feed. The stitch length is adjustable using a knob. The backward stitching is controlled by a hand lever, eventually, by pedal or by electromagnet in accordance with the equipment of the machine. The position and the width of the zig-zag stitch are adjustable by levers situated on the machine arm. The presser foot lifting is controlled by a hand lever, eventually, by pedal, or by a knee lever or by electromagnet in accordance with the machine equipment.

The machine is provided with a large diameter horizontal hook. It has a 1.8 x greater reserve (volume) of threads than a standard hook. The lubricating system of the machine is of a group wick-feed type with automatic regreasing of the hook.

### 3. Machine subclasses

Table 1

Machine type	Hook	Presser foot lifting		Backtacking			Thread trimmer
		Via knee lever or pedal	Via electro-magnet	Via hand lever	Via pedal	Via electro-magnet	
524-101	●	●		●	●		
524-105	●	●	○	●	●	○	●

- standard equipment
- optional equipment

### 4. Survey of equipment

This survey does not include the equipment assembled on the stand (see part B).

#### 4.1 -for the subclass -101

##### 4.1.1 Necessary equipment

S791 995068                      Parts of backtacking (with pedal)

##### 4.1.2 Sewing equipment

S791 124032 35                  Sewing equipment 525 E 032  
 S791 124033 35                  Sewing equipment 525 E 033 - standard  
 S791 124034 35                  Sewing equipment 525 E 034  
 S791 224075 35                  Sewing equipment 525 E 075

### 4.1.3 Optional equipment

S791 149001	Attachment for serging operation
S791 151016	Hinged foot with front thread slit - zig-zag stitch width 6 mm
S791 151017	Hinged foot with front thread slit - zig-zag stitch width 10 mm
S791 947001	Adjustment gauges
S794 222012	Sewing lamp
S741 610118 40	High mortality spare parts kit in a plastics box

## 4.2 -for the subclass - 105

### 4.2.1 Necessary equipment

S791 995068	Parts of backtacking (with pedal)
S980 094051	Connecting cable to drive EFKA DC 1600/DA82GA and EFKA VD 552/6F82FA

### 4.2.2 Sewing equipment

S791 124032 35	Sewing equipment 525 E 032
S791 124033 35	Sewing equipment 525 E 033
S791 124034 35	Sewing equipment 525 E 034 - standard
S791 224075 35	Sewing equipment 525 E 075

### 4.2.3 Optional equipment

S791 149001	Equipment for overedging
S791 151016	Hinged foot with front thread slit - zig-zag stitch width 6 mm
S791 151017	Hinged foot with front thread slit - zig-zag stitch width 10 mm
S791 947001	Adjustment gauges
S794 222012	Sewing lamp
S791 995153	Presser foot lift via electromagnet
S791 995154	Backtacking via electromagnet
S980 094057	Push button for backtacking EFKA DC 1600/DA82GA
S980 094060	Push button for backtacking EFKA VD 552/6F82FA
S741 610518 40	High mortality spare parts kit in a plastics box

## 5. Technical data

Sewing speed	4400 SPM - maximum 3500 SPM - standard
Stitch type	double-thread zigzag lockstitch - 304
Stitch length	max. 5 mm
Zig-zag stitch width	max. 10 mm
Presser foot lifting	5 mm - via hand lever 7 mm - via knee lever, pedal, electromagnet
Hook	S980 008250 - horizontal, large diameter
Needle	system 134 No. 80-110
Drive	clutch motor 2800 RPM (min. 0,35 kW) stop motor (min. 0,4 kW)
Head weight	max. 38 kg
Stand weight	61 kg
Opening space of machine head	265 x 120 mm
Bedplate dimension	178 x 476 mm
Length of trimmed thread ends	up to 20 mm
Machine power input with clutch motor	max. 700 W
Machine power input with stop motor	max. 800 W
Equivalent sound pressure level of the machine alone at the working spot with 20 % utilization of the machine during the working shift at the standard sewing conditions	83 dB/A
Ground plan machine dimensions (including stand)	1060 x 550 mm
Machine height (including stand and thread stand)	1490 mm

## 6. Operation of the machine



### Caution!

Do not use this sewing machine without using the finger guard (C, Fig. 4) and without the take-up lever guard (P, Fig. 2).

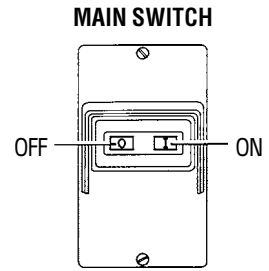

### 6.1 Upper thread threading (Fig. 1, 2)



### Caution!

Before starting the threading operation, switch off the main switch and put off the feet from the pedals on the stand to avoid the starting of the machine by treading the pedal.

After having inserted the bobbin with thread on the thread stand (N), unwind the thread in sufficient length and pass it through the holes in the thread stand (N). Direct it then through the thread guide (A) and through the guide (B) - with the machines without any thread cutter, or through the auxiliary thread tensioner (L) with the machines provided with such thread cutter. Feed the thread between the dishes of the tensioner (C). Direct the thread through the adjusting spring (D) around the guide (E) and through the guide (F) and (G) into the take-up lever eye (H). From here the thread is directed downward through the guides (F) and (J) and through the hole of the thread guide (K) on the needle bar towards the needle eye. Thread the thread into the needle eye from the front (from the sewer) rearward.

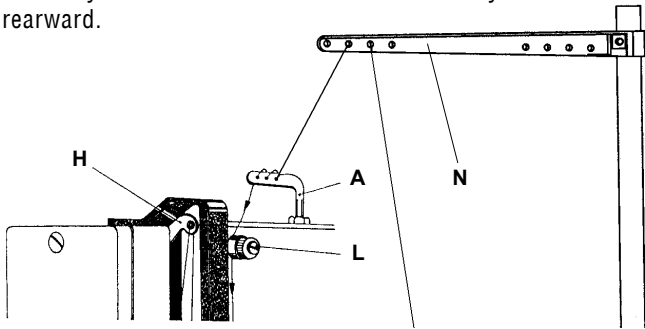

Fig. 1

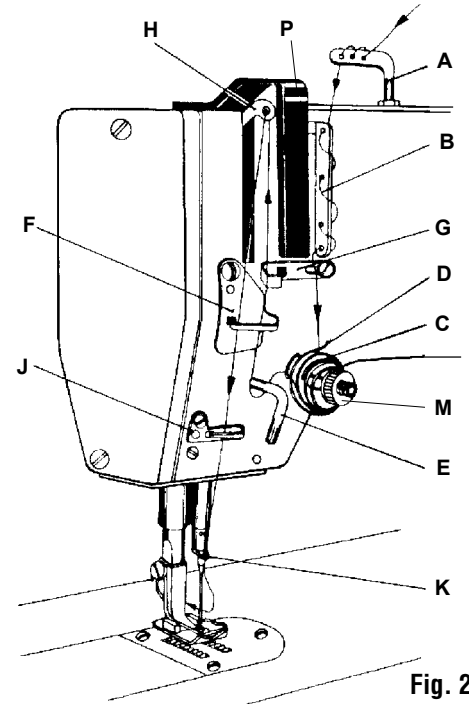

Fig. 2

### 6.2 Winding of thread on the hook bobbin (Fig. 3)

From the thread stand the thread is directed to the tensioner (A) through the guide (B) on the machine head. From the guide the thread is directed on the hook bobbin mounted on the shaft (C) of the winder. Wind up the thread end several times on the bobbin in the clockwise direction and feed it towards the spring (D). Introduce the thread between the coils thereof and, when pulling it slightly, cut it with the knife which is mounted inside the spring. Engage the winder by means of the lever (E). After having wound up the thread on the bobbin, the winder stops automatically. After having removed the bobbin from the winder shaft it is possible to cut the thread with the knife protected by the spring (D) or to cut it with scissors. The thread (A) serves for regulating the tension of the thread for winding.

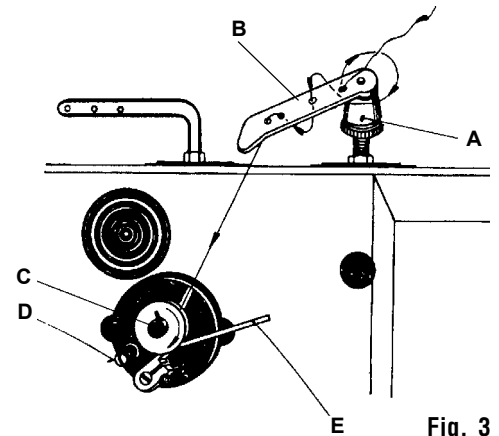

Fig. 3

### 6.3 Needle insertion (Fig. 4)



### Caution!

Before starting the operation of the needle change, switch off the main switch and put the feet off the pedals on the stand to avoid the machine start by treading the pedal.

After having chosen the correct needle thickness (number) corresponding to the system of the prescribed type (usually the system 134), loosen the screw (A) in the needle holder and insert the needle (B) up to the bottom of the hole in the needle holder. Turn it in such a way, so that its long groove is directed ahead (towards the sewer).

Caution - when choosing a thicker needle it is necessary to check, whether the hook beak does not catch the needle - the eventual setting of the hook position is to be carried out by a qualified person. Check up, whether the needle passes through the centre of the needle hole, change a faulty needle.

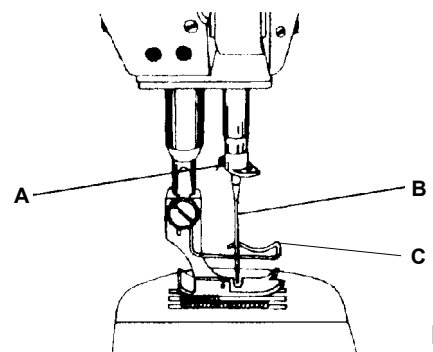

Fig. 4

## 6.4 Adjustment of the upper thread tension (Fig. 1, 2, 5)

The tension of the upper and that of the bottom thread must be mutually adjusted in such a way, so that the stitch locking is being done in the middle of the sewn material (Fig. 5). The tension of the upper thread is to be adjusted by turning a bit the nut of the tensioner (M, Fig. 2). In turning the nut to the right (in the clockwise direction), we increase the tension of the upper thread, in turning it in the opposite direction, we reduce the tension of the thread.

When the machine is provided with a thread cutter of thread (version -105), its correct function is to be given major attention in adjusting correctly the thread tension. It is necessary to set correctly the auxiliary tensioner (L, Fig. 1) the function of which influences the length of the upper thread end which is projecting from the needle eye after having cut the thread. When correctly setting of the tensioner, the quality of the initial stitches is good and no unthreading of the thread out from the needle occurs.

When increasing the adjusted tension of the auxiliary tensioner this end is shorter (the seam starts are of better quality), but there is an increased danger that this length will not be sufficient for starting further stitching, when the thread would leave the needle eye. In the opposite case, namely with a too small tension, the given ends are uselessly too long which worsens the quality of the stitch start on the rear side of the sewn material.



Correct adjustment of the tension of both threads



Incorrect adjustment

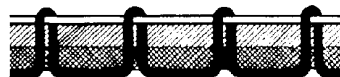

Incorrect adjustment

Fig. 5

## 6.5 Change of the hook bobbin, threading and setting of the bottom thread tension (Fig. 6, 7)



### Caution!

Do not start the machine before placing the hook covers in their working (protective) position.

Before changing the bobbin in the hook, switch off the main switch and put your feet off the pedals on the stand to avoid the machine start by treading the pedal.

Using the flap (F), remove the bobbin case from the hook.

Put the full bobbin (A) into the bobbin case (B) and guide the thread through the groove (C) under the braking spring (D) and then into the hole (E).

Let free about 5 – 6 cm of the thread end. It is recommended to turn the bobbin in the arrow direction when pulling the thread. After having inserted the bobbin case into the hook be sure in assuring this by the flap (F). As usual, by means of the the upper thread, we thread the bottom thread above the throat plate.

The tension of the bottom thread is regulated by a screw (G). In turning it in the (+) direction, the pulling power increases, in the (-) direction it is reduced. When the tension of the bottom thread is correctly adjusted, then a good stitch laying is generally being ensured by the respective adjustment of the upper thread tension by means of the tensioner nut.



Fig. 6

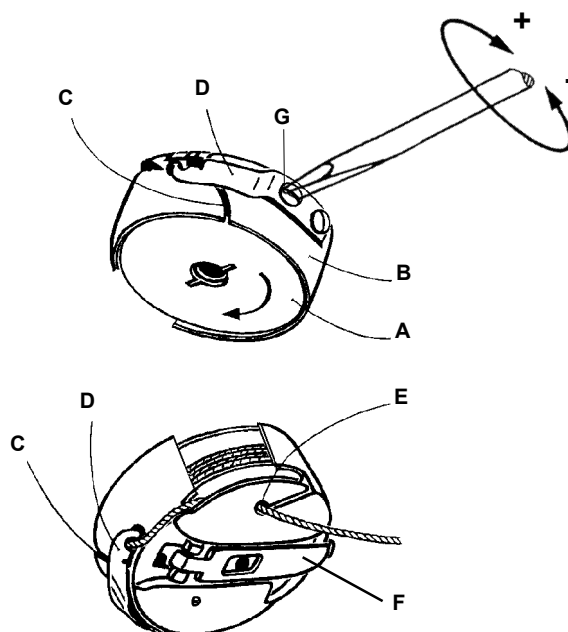

Fig. 7

## 6.6 Adjustment of the stitch length, reverse stitching (Fig. 8, 9)

The stitch length is changed in turning the knob (A), which is placed on the arm web, according to the numbers indicating the stitch length against the symbol (B) on the machine arm. In turning the knob in the direction of the arrows, the stitch length is increased (+) or reduced (-).

The direction change of feeding the stitched material is mechanically controlled by the reversible stitch lever (C) in pushing it in the direction of the arrow (S).

According to the chosen accessory, the machine can be provided with an electromagnetic backtacking control (see Part B, par. 8) or with a control by a backward stitch pedal (P).

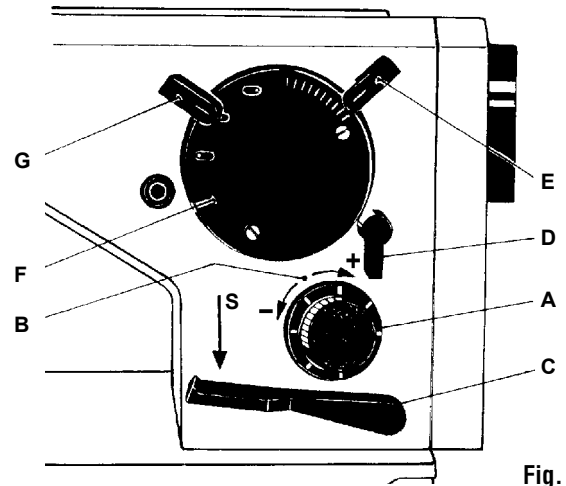





Fig. 8

## 6.7 Adjustment of the zigzag stitch width and position (Fig. 8)

Before any change of the zigzag stitch width or before changing the zigzag stitch position the machine is to be stopped in such a way, so that the needle is in its top position. Further it is necessary to turn a bit the arresting lever (D) to the left (in counterclockwise direction) and to have it loosened until having proceeded the required change of adjustment. In turning a bit the lever in the opposite direction (to the right) there occurs the blocking of the adjusted width and position of the zigzag stitch.

The width of the zigzag stitch is continuously adjustable according to the machine types from 0 up to 10 mm. It is adjusted by the lever (E) projecting above the cover (F) of the zigzag stitch mechanism. In moving the lever to the right (towards the hand wheel) we increase the width of the zigzag stitch up to the maximum, in moving the lever to the left, we reduce the width of the zigzag stitch up to zero. The position of the zigzag stitch is adjusted by the lever (G) projecting on the side of the cover (F) of the zigzag stitch mechanism.

The basic (middle) zigzag stitch is adjusted with the middle position of the lever (G) on the mark . In this position, the lever fits into the arresting slot. If we want to sew with a zigzag stitch to the right, we shall shift this lever, after having slightly depressed it in the direction from the sewer and upwards up to the stop towards the mark . When adjusting the left zigzag stitch, we shift this lever again after having slightly depressed the lever in the direction from the sewer up to the stop towards the mark . After having ended the adjustment of the desired stitch position, we turn a bit the arresting lever (D) to the right in securing so the chosen stitch position. When using the machine for sewing using straight stitch, we recommend to use it with the adjustment of the middle zigzag stitch on the mark .



P

Fig. 9

## 6.8 Regulation of the presser foot pressure, presser foot lifting (Fig. 10)

The pressure of the presser foot is regulated using an adjusting screw in the hole (A) which is placed below the top cover of the machine arm and is accessible from above through the hole in this cover. In turning the adjusting screw in the direction of the arrows we increase (+) or reduce (-) the pressure of the presser foot. The pressure of the presser foot must be sufficient for ensuring a reliable and continuous feeding of the sewn material with the maximum sewing speed. A correct adjustment of the pressure of the pressure bar influences, whether the sewn material is being continuously fed without any damage and whether the stitch length is uniform.

The mechanical lifting of the presser foot is enabled by means of the hand lever (B) which when lifted arrests the presser foot in its top position. The presser foot can be lifted with the knee lever or with the left pedal too - according to the machine subclass.

The assembling procedure of the automatic presser foot lifting using electromagnet is described in the part B, par. 7.

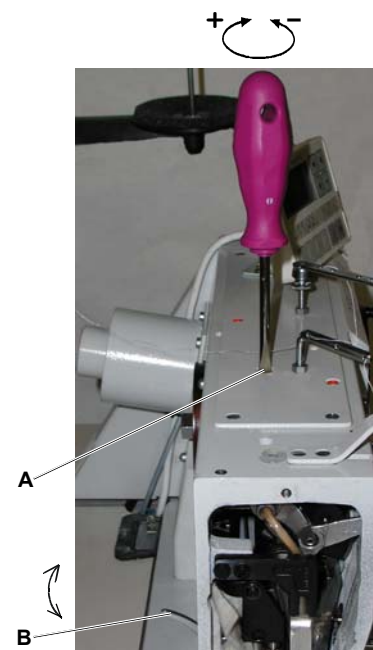

Fig. 10

## 7. Machine maintenance



### Caution!

Before cleaning and lubricating the machine switch off the main switch and put your feet off the pedals on the stand to avoid starting the machine by treading the pedal.

### 7.1 Cleaning

Maintain the machine clean and at least once a day (according to the processed material) remove dirt from the hook and feeder space by means of a brush, with the machines provided with a thread cutter, from the cutting space as well. Avoid using volatile liquids for cleaning purposes, they damage the machine and the health too. Check up the filtering sieve on the electric motor for not being choked with dust.

### 7.2 Lubrication (Fig. 11, 12, 13)

For lubricating the machine use Esso SP-NK 10 oil or another oil of the same quality (viscosity at 40° C: 10 mm<sup>2</sup>/s; inflammation point: 150°C). Before starting the stitching operation, put one oil drop into the holes marked with red colour on the machine (Fig. 12, 13). Check up specially the oil level on the oil level gauge (1) for lubricating the hook. Refill oil through the hole (2) above the oil level gauge only when the oil lever considerably sinks below the middle of the oil level gauge.

From time to time, oil is to be dropped into the hole of the hook gearbox (Fig. 13). The quantity of the oil fed for lubricating the hook is regulated by turning a bit a regulation pin (3) using a screwdriver within the extent of 0 - MAX, that is to the left, in counterclockwise direction. The pin is placed on the front side of the oil vessel under the bedplate. When setting the indicator of the regulation pin on "0", the minimum oil feeding to the hook is ensured, so that its seizure is avoided. After having put the machine into operation, check and refill regularly the oil level in the oil vessel at the hook and in the oil vessel on the machine arm. It is necessary to refill ESSO BEACON EP2 grease in the shafts of the feeding mechanism (4, 5).

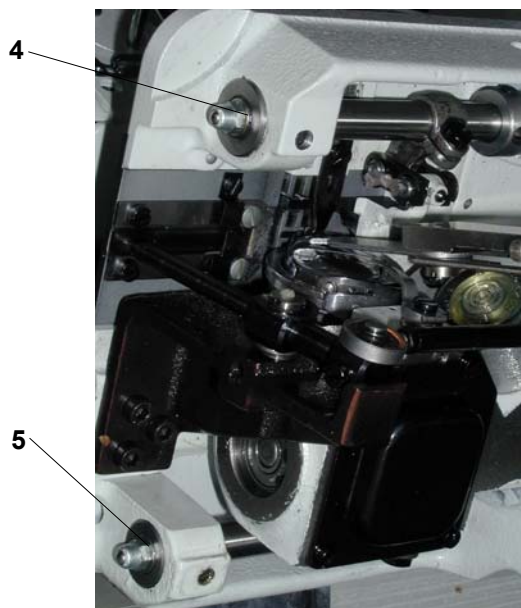

Fig. 11



Fig. 12

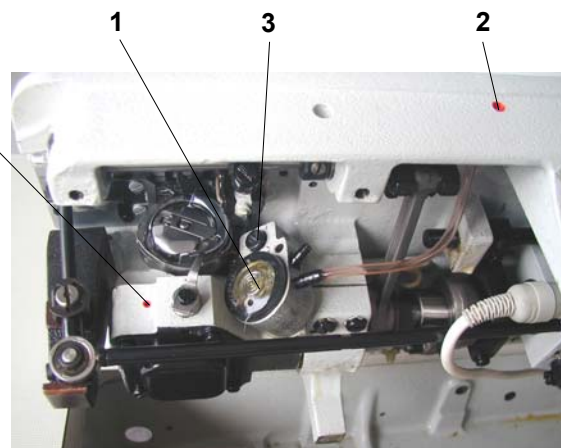

Fig. 13

## 8. Electronic control of the machine

(it is valid for sub-classes equipped with stop motor)

### 8.1 Control of sewing by means of control elements

#### 8.1.1 Via treadle (treadle positions and function possibilities) (Fig. 14)

The position of the treadle is read by the reader, which can recognise 16 levels. Its meaning is shown on the table and see Fig. 14.

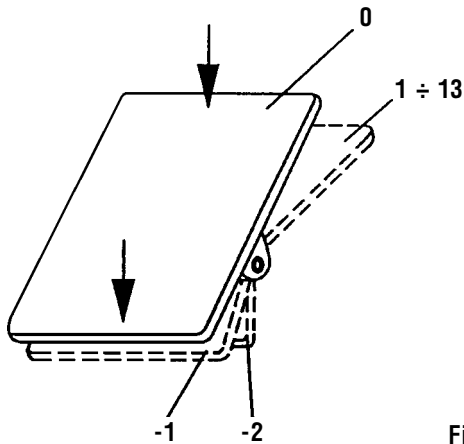

Fig. 14

Treadle position	Treadle	Meaning
-2	Foot full backwards	Command for thread trimming (seam finishing)
-1	Foot slightly	Command lifting the foot up
0	Neutral position	Note
1	Slightly forwards	Command releasing foot
2	Continually forwards	Sewing at minimum speed (1. gear)
3	Continually forwards	Sewing at second speed level
:	:	:
13	Fully forwards	Sewing at maximum speed (12. gear)

*Note:* It is possible to pre-adjust the needle position (up/down) and foot position (up/down) by stopping in seam (introducing the treadle in neutral position). Foot position (up/down) after seam finishing (pressing the treadle by foot fully backwards).

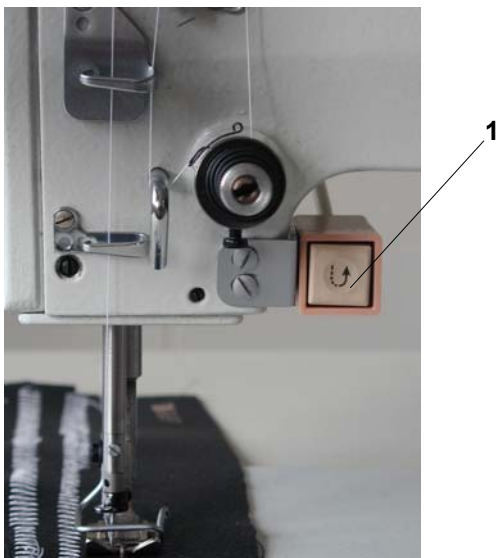

Fig. 15

#### 8.1.2 Via pushbutton (Fig. 15)

The pushbutton has got a firmly set function of bar operation (when depressing the push button during the sewing operation, the sewn material is being reverse fed).

#### 8.1.3 Via control panel Efka V 810/V 820 (Fig. 16, 17)

These functions are standardly assigned to the pushbuttons A, B:

- A - cancelling (recalling) the bar
- B - needle up/down

*Note:* Function of the A,B pushbuttons can be changed by different adjustment of parameters 293,294 (see original operating instruction Efka DA82GA).



Foot position adjustment by stopping at the seam (by neutral position of treadle) and after finishing seam (by neutral position of treadle):

Setting is by means of pushbutton 3, arrow indication above the corresponding symbol.

Needle position adjustment by stopping at the seam:

Setting is by means of pushbutton 4.

### 8.2.1.2 Setting by means of parameters (Fig. 16)

Drive memory contains the parameters which enables sewing system tuning. These parameters have exact meaning and they are divided into 3 levels. Further parameters which are available only for operation will be quoted. Each parameter has its (sequence) number and value.

General procedure by changing parameters of operation level:

- switch the main switch on or finish the seam by pressing the treadle fully backwards down
- press pushbutton P on the panel V 810
- it will be displayed on the display F 000 (000 it is the number of parameter)
- by several times pressing + (or -) set the requested number of parameter
- push pushbutton E down and it will be shown the value of parameter on the display
- you can change the value by means of pushbutton + or -
- by pushing pushbutton E down you will change the sequence to the following number of parameter
- by pushing pushbutton P down you will leave the mode of changing parameters

*Note:* 1. For permanent memory storing of changed parameter, it is necessary to press treadle forwards down after changing of parameters.

2. Mode of changing parameters is possible only after finishing of the seam.

Number of stitches in bars:

Number of stitches is stored in parameter's number.

No. of parameter	Value range of parameter	Description of parameters
000(080)	0-254	Number of stitches of start (fancy) bar forwards
001(081)	0-254	Number of stitches of start (fancy)bar backwards
002(082)	0-254	Number of stitches of end (fancy) bar backwards
003(083)	0-254	Number of stitches of end (fancy)bar forwards

Sewing according to sewing program:

Drive with panel V810 automatically enables sewing of 1 seam with setting number of stitches. It is necessary to set in corresponding number of stitches, and initialisation of sewing program.

No. of parameter	Value range of parameter	Description of parameters
007	0-254	Number of stitches
015	ON/OFF	ON/OFF sewing under sewing program

ON/OFF thread trimmer:

No. of parameter	Value range of parameter	Description of parameters
013	ON/OFF	Thread trimmer ON/OFF

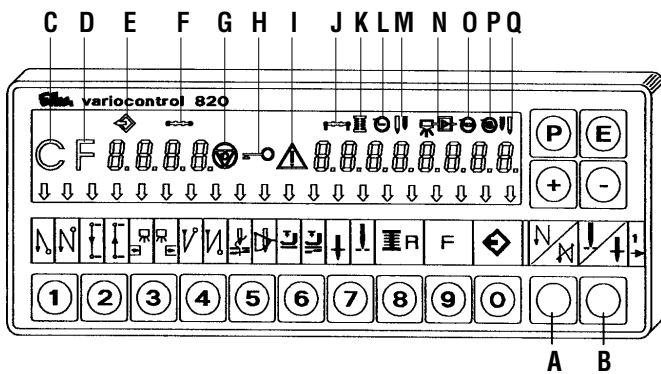

Fig. 17

## 8.2.2 By using stop motor Efka with panel V 820 (Fig. 17)

### Functioning pushbuttons engagement:

Pushbutton P	Call and termination of programming mode
Pushbutton E	Confirmation when changing programming mode
Pushbutton +	Increasing the value displayed in programming mode
Pushbutton -	Reducing the value displayed in programming mode
Pushbutton 1	Start bar SINGLE/DOUBLE/OFF
Pushbutton 2	Stitch counting FORWARD/BACK/OFF
Pushbutton 3	Light barrier function LIGHT-DARK/DARK-LIGHT/OFF
Pushbutton 4	End bar SINGLE/DOUBLE/OFF
Pushbutton 5	Function TRIMMING/TRIMMING+EJECTOR/OFF
Pushbutton 6	Automatic foot lifting after having stopped inside the seam ON/OFF Automatic foot lifting after trimming ON/OFF
Pushbutton 7	Basic needle position UP/DOWN
Pushbutton 8	Lower thread waste controlling ON/OFF
Pushbutton 9	Operation pushbutton - programmable
Pushbutton 0	Programming/processing of 40 possible sewing sections (seams)
Pushbutton A	For cancelling or calling the bar
Pushbutton B	For switching needle position UP/DOWN, resp. shifting pushbutton in the programming mode
Symbol C	Designating symbol C for code number
Symbol D	Designating symbol F for parameter number
Symbol E	Programme number in TEACH IN mode
Symbol F	Seam number in TEACH IN mode
Symbol G	Run blocking ON
Symbol H	Blocked insertion by pushbutton
Symbol I	Fault reporting
Symbol J	Insertion of stitch number in TEACH IN mode
Symbol K	Connected lower thread controller, flashing symbol when running out thread reserve on bobbin
Symbol L	Limitation of revolutions ON
Symbol M	Right needle disconnected
Symbol N	Evening stitches for light barrier in the TEACH IN mode
Symbol O	Machine is running
Symbol P	Automatic revolutions ON
Symbol Q	Left needle disconnected

The arrows on the display indicate switching the functions which are displayed by symbols above the pushbuttons on.

### 8.2.2.1 Adjustment by means of buttons with fixed setting function (Fig. 17)

*Note:* It is important to finish the seam in order to reach effective button pressing (press the treadle fully backwards down).

#### Setting start bar:

Drive enables sewing start bar automatically. It is necessary to choose the type (single, double, off) and number of stitches which will be sewn forwards and backwards.

The arrow above its symbol shows the type of bar (chosen by gradually pressing pushbutton 1). It will be displayed following after pressing pushbutton 1.

Arv (SAv) XXX - number of stitches of start (fancy) bar forwards or

Arr (SAr) XXX - number of stitches of start (fancy) bar backwards for about 3 sec.

At this time you can change the number of stitches by gradually pressing the pushbutton + or -.

#### Setting end bar:

The same applies to the start bar (setting by the means of pushbutton 2).

Erv (SEv) XXX - end (fancy) bar number of stitches forwards

Err (SEr) XXX - end (fancy) bar number of stitches backwards

*Note:* The last section of end bar must have at least 3 stitches.

#### Foot position adjustment by stopping at the seam (by neutral position of treadle) and after finishing seam (by neutral position of treadle):

Setting is by means of pushbutton 6, arrow indication above the corresponding symbol.

#### Needle position adjustment by stopping at the seam:

Setting is by means of pushbutton 7.

#### Trimming switched ON/OFF:

To be set using pushbutton 5.

#### Sewing programme ON:

To be switched on using pushbutton 0.

#### Switching ON/OFF the function of the pushbutton F:

The pushbutton F on panel can have assigned one of the following functions: Sst - softstart

SrS - fancy bar

Frd - reverse angle after trimming

### 8.2.2.2 Setting by means of parameters (Fig. 17)

Drive memory contains the parameters which enables sewing system tuning. These parameters have exact meaning and they are divided into 3 levels. Further parameters which are available only for operation will be quoted. Each parameter has its (sequence) number and value.

General procedure by changing parameters of operation level:

- switch the main switch on or finish the seam by pressing the treadle fully backwards down
- press pushbutton P on the panel V 820
- on the display there is no data shown
- by depressing the pushbutton E several times, set the required parameter (without having displayed the parameter number)
- you can change the value using pushbuttons + or -
- by depressing the pushbutton E you will pass in the given sequence to the following parameter
- by depressing the pushbutton P down you will leave the mode of changing parameters

- Note:**
1. For permanent memory storing of changed parameter, it is necessary to press treadle forwards down after changing of parameters.
  2. Mode of changing parameters is possible only after finishing of the seam.

Number of stitches in bars:

Number of stitches is stored in parameter's number.

No. of parameter	Value range of parameter	Description of parameters
000(080)	0-254	Number of stitches of start (fancy) bar forwards
001(081)	0-254	Number of stitches of start (fancy) bar backwards
002(082)	0-254	Number of stitches of end (fancy) bar backwards
003(083)	0-254	Number of stitches of end (fancy) bar forwards

The drive with the panel V 820 enables sewing automatically up to 40 seams distributed up into eight programmes with the given stitch numbers and sewing direction (forwards/rearwards). For more detailed information see the original driving instructions.

## Operating instructions for eventual trouble shooting

Note: When the machine is driven by a stop motor, it is indispensable to check up, before starting its repair, the setting of its parameters according to Instructions for assembling, part B, par. 12.5.2.

Trouble	Cause	Method of troubleshooting
1. Machine runs with difficulty.	1.1 Machine out of use for certain time, dried oil and dirt in bearings.	Inject some drops of kerosene into all oiling holes and on sliding surfaces and put the machine in quick running to clean out the oiling holes in the bearings. Lubricate then the machine with oil for sewing machines according to par. 7, part A.
2. Machine starts with slow running.	2.1 Insufficient tension of the belt from electric motor.	Tension the belt according to par. 5.1.2, part B.
3. Upper thread tearing.	3.1 Thread guides incised. 3.2 Sharp hook point. 3.3 Bad feeding. 3.4 Incorrect guiding or upper thread threading. 3.5 Excessive thread tension. 3.6 Needle incorrectly mounted or damaged. 3.7 Thread thickness does not answer the thickness of sewn material. 3.8 Machine excessively dirty.  3.9 Thread wound up on the hook.  3.10 Thread too thin or insufficiently resistant.	Check up and replace the guides. Repair. Set tension according par. 3; 6; 7, part C. Thread upper thread according to par. 6.1, part A. Set tension according par. 6.4, part A. Replace needle according to par. 6.3, part A. Use more suitable thread.  Unscrew throat plate and clean out the mechanism. Remount the throat plate according to the par. 5, part C. Remove thread.  Use a more suitable thread.
4. Lower thread tearing.	4.1 Incorrect threading of the thread in the bobbin case. 4.2 Thread too weak or insufficiently resistant. 4.3 Thread incorrectly wound up on the hook bobbin. 4.4 Bobbin damaged. 4.5 Sharp pressure spring on the bobbin case.	Thread correctly the thread according to par. 6.5, part A. Use a more suitable thread.  Rewind the bobbin.  Replace bobbin. Replace spring.
5. Skipping of stitches.	5.1 Needle incorrectly mounted. 5.2 Needle blunt or bent. 5.3 Hook point incised or broken. 5.4 Big needle hole in throat plate. 5.5 Broken adjusting spring for tensioning upper thread. 5.6 Needle bar too high or too low. 5.7 Hook overrun, incorrect timing adjustment. 5.8 Dirty hook mechanism.	Insert correctly needle according par. 6.3, part A. Replace needle according to par. 6.3, part A. Replace hook. Replace throat plate and mount it according to par. 5, part C. Replace spring and set upper thread tension according to par. 6.4, part A. Set according to par. 10, part C. Adjust hook timing according to par. 11, part C. Clean out with kerosene and lubricate with oil.
6. Needle breaking.	6.1 Feeder too high. 6.2 Negligent sewing, pulling of the material.	Set the feeder height according to par. 3, part C. Let material pass freely.

	6.3 Needle too thin for thick material.	Replace needle according to par. 6.3, part A.
	6.4 Needle incorrectly mounted.	Mount correctly needle according to par. 6.3, part A.
	6.5 Throat plate loosened.	Mount throat plate according to par. 5, part C.
	6.6 Upper thread tension too high.	Set tension according to par. 6.4, part A.
7. Difficult and uneven machine feeding.	7.1 Feeder too low.	Set the feeder height according par. 3, part C.
	7.2 Feeder used.	Replace.
	7.3 Feeder teeth fouled or blunt.	Clean or replace feeder.
	7.4 Insufficient presser foot pressure.	Increase pressure according to par. 6.8, part A.
8. Incorrect stitch locking. Threads locked on the top side of sewn material.	8.1 Incised spring on bobbin case, lower thread insufficiently braked.	Replace spring.
	8.2 Lower thread not threaded under bobbin case spring.	Rethread thread according to par. 6.5, part A.
	8.3 Lower thread retained under the bobbin case spring.	Clean.
	8.4 Unequal setting of upper and lower thread tension.	Set thread tension according to par. 6.4 and 6.5, part A.
	8.5 Machine feeds too soon.	Set feeding according to par. 3; 6; 7, part C.
9. Incorrect stitch locking. Threads locked on the bottom side of sewn material.	9.1 Tensioning disks incised by upper thread.	Replace disks and set upper thread tension according to par. 6.4 and 6.5, part A.
	9.2 Thread does not pass around hook or is retained by the bobbin case.	Clean hook and set up bobbin case.
	9.3 Upper thread not threaded between the tensioning disks.	Thread correctly the thread according to par. 6.1, part A.
	9.4 Lower thread retained between the tensioning disks.	Clean thread tensioner and set it according. 6.4, part A.
	9.5 Unequal setting of upper and lower thread tension.	Set correctly according to par. 6.4, part A.
10. Hook blocked.	10.1 Lower thread wastes retained in hook.	Move hand wheel in spite of considerable resistance in both senses until the threads in the hook get cut up. After having removed them, let run the machine unthreaded a while and then lubricate the hook with 2-3 drops of oil recommended in the par. 7, part A.
11. Little reserve of upper thread, machine does not start sewing, upper thread leaves needle eye at the start of next sewing.	11.1 Excessive tension of auxiliary tensioner.	Reduce tension according to par. 6.1, part A.
	11.2 Cam time setting too quick.	Delay according to par. 23, part C.
	11.3 Machine stops before upper dead center.	Set according 29, part C.
	11.4 Electromagnet loosening main tensioner is out of function.	Find out the cause and repair.
	11.5 Incorrect upper thread unwinding.	Repair.
12. Little reserve of lower thread, machine does not start sewing.	12.1 Lower thread end drawn into bobbin case.	Increase lower thread winding up tension according to par. 6.2, part A.
	12.2 Excessive winding up speed.	Maintain maximum number of revolutions 140/min.
	12.3 Excessive lower thread tension.	Reduce according to par. 6.5, part A.
	12.4 Burr on the covering hook sheet.	Polish up.
13. Thread ends untrimming or insufficiently trimming.	13.1 Incorrectly set up (little) pressure of fixed knife.	Set according to par. 28, part C.
	13.2 Blunt fixed or trimming knife.	Replace or sharpen.

14. Low quality of stitch start on rear side.	14.1 Upper thread end too long.	Increase tension of auxiliary tensioner according to par. 6.1, part A. Adjust time setting of cam according to 23, part C.
15. No upper or lower thread trimming.	15.1 Incorrect cam time setting. 15.2 Skipped stitches with slow machine revolutions. 15.3 Incorrect thread division with trimming knife. 15.4 Low lifting of trimming knife.	Set correctly cam according to par. 23, part C. Set up. Set or replace trimming knife according to par. 27; 32, part C. Set up according to par. 27, part C.
16. No upper and lower thread trimming, but machine rotates from lower to top position.	16.1 Incorrect cam time setting. 16.2 Incorrect function of electromagnet for trimming control (it gets seized). 16.3 Insufficient trimming knife lifting.	Set cam correctly according to par. 23, part C. Check up connection-replace eventually electromagnet. Set up according to par. 24, part C.
17. Machine starts sewing only after having skipped some stitches.	17.1 Insufficient upper thread reserve. 17.2 Insufficient lower thread reserve.	Set up according to par. 6.1, part A; par. 23 and 29, part C. Polish up trimming knife and hook.
18. When starting sewing operation, upper thread end projects above the sewn material.	18.1 Upper thread reserve too big.	Increase tension of auxiliary tensioner according 6.1, part A. Change cam time setting according 23, part C. Adjust machine stopping with needle bar in top dead centre according par. 29, part C.

## Contents - part B - The instructions for assembling:

<b>1. Safety instructions</b> .....	1
<b>2. Method of delivering the machine</b> .....	1
2.1 Complete head with accessories .....	1
2.2 Stand .....	1
2.3 Motor .....	1
2.4 Motor pulley .....	2
<b>3. Stand table top</b> .....	2
<b>4. Assembly of the stand frame and height setting</b> .....	2
<b>5. Assembly and screwing on of the stand table top</b> .....	5
5.1 Assembly of stand table top .....	5
5.1.1 Placing of the machine head on the stand .....	5
5.1.2 Assembly of motor pulley, belt, belt covers .....	5
<b>6. Mounting of a position reader and of a control panel of the stop motor</b> .....	6
<b>7. Mounting of the equipment for presser foot lifting using electromagnet</b> .....	6
<b>8. Mounting of the equipment for backward stitching</b> .....	7
<b>9. Mounting of the lighting</b> .....	7
<b>10. Composition and assembly of the thread stand</b> .....	8
<b>11. Preparation of the machine for sewing</b> .....	8
<b>12. Instructions for putting the electronically controlled drive into operation</b> .....	9
12.1 Power supply 1 x 230 V - DC motor .....	9
12.2 Power supply 3 x 400 V - five wire power distribution, power supply 3 x 230 V - four wire or five wire power distribution .....	10
12.3 Power supply 3 x 400 V - four wire power distribution plus 1 x 230 V - two wire cable .....	10
12.4 Electrical connection of machine head to the stop motor .....	11
12.5 Stop motor setting S359 600045 XXX - EFKA DC 1600/DA82GA .....	13
12.5.1 Setting position reader .....	13
12.5.2 Changes of setting parameters of stop motor setting considering original producer ssetting .....	13
12.6 Stop motor setting S359 600052 XX - EFKA VD 552/6F82FA .....	13
12.6.1 Setting position reader .....	13
12.6.2 Changes of setting parameters of stop motor setting considering original producer setting .....	14

## Part B - Instructions for assembling

### 1. Safety instructions

**Caution!**

The assembly of the machine is to be done only by a trained mechanician.  
All operations connected with the electric installation of this sewing machine are to be done only by an authorized electromechanician. It is absolutely necessary to get acquainted with the instructions concerning the drive supplied by the manufacturer thereof.

### 2. Method of delivering the machine

The content of the delivery is given by the agreement between the supplier and the buyer. There are the following possibilities:

#### 2.1 Complete head with accessories

In this case the delivery contains:

- Complete head.
- Selected spare parts.
- Standard accessories (containing tools – see catalogue of spare parts).
- Special accessories (containing some components of the stand - see catalogue of spare parts).

#### 2.2 Stand

The delivery contains components of the stand, but without the stand components contained in the special accessories delivered with the machine head (see par. 2. 1) and without any electric components.

When not otherwise agreed, the stand will be delivered in disassembled state. When an assembled stand is required, then special accessories from the head delivery will be used.

Stand complete (ordered number S072 500100 for subclasses -101 and -105) contains following items:

MG53 000501	Stand frame
MG53 002501	Big pedal
MG53 007511	Set of parts for stand
S615 000316	Stand table top

Equipments for stand (it has to be ordered separately):

Presser foot lifting by pedal:

S522 000450	Small pedal
S980 044982	Presser foot lifting draw bar

Reverse stitching:

S522 000450	Small pedal
S980 060028	Reverse stitching draw bar

#### 2.3 Motor

The delivery contains the proper motor, switch - circuit breaker, complete cabling (except of the plug) and connecting material. According to the motor type, it may contain a control panel. When not otherwise agreed, it is delivered in disassembled state. The machine without thread cutting device is provided with a clutch motor with lever. When positioning or presser foot lifting or backward stitching with electromagnet are required, the machine without thread cutting device must be provided with a stop motor.

Motors are to be chosen according to the following table:

Machine subclass	Ordered number	Name	ř of pulley mm	Machine rev. max./min	Approx. specification
101	S359 600030 88	FIR 1148	88	3800	asynchronous bipolar clutch motor switch-circuit breaker with cabling connection material
	S359 600030 75	3 x 400/230 V, 50/60 Hz	75	3200	
	S359 600030 58		58	2500	
105	S359 600045 810	Stopmotor EFKA	58	adjustable adjustable	D-C motor (A-C servo); switch-circuit breaker control panel EFKA V 810/V820 connection material and cabling
	S359 600045 820	DC 1600/DA82GA 1 x 230 V, 50/60 Hz	58		
	S359 600052 88	Stopmotor EFKA	88	3800	asynchronous bipolar stopmotor with friction clutch and brake switch-circuit breaker with cabling connection material control panel EFKA V 810/V820 *
	S359 600052 75	VD 552/6F82FA	75		
	S359 600052 58	3 x 400/230 V, 50/60 Hz	58		

\* Control panel S359 600038/V810 or S359 600050/V820 it is possible to order for setting the stop motor, however, it is not included in supply of the stopmotor and it has to be ordered separately.



The given stop motors have been tested on the machine and comply with the functional requirements. Other types of stop motors may or may not have suitable parameters. The manufacturer thereof does not recommend any use of different stop motor without having tested it.

## 2.4 Motor pulley

By stopmotor EFKA DC 1600/DA82GA is revolutions are set continuously by electronics.

The pulley for the maximum or other sewing speed will be supplied on express wish of the customer.

The pulley are to be chosen according to the following table:

Motor	Sewing speed	Sewing speed	ř of pulley mm	Ordered number of pulley
	50 Hz	60 Hz		
FIR 1148/552/3 EFKA VD552	1810	2170	42	S980 045548
	2020	2430	47	S980 045377
	2150	2580	50	S980 045491
	2330	2790	54	S980 045361
	2500	3000	58	S980 045472
	2710	3260	63	S980 045378
	2890	3460	67	S980 045476
	3020	3620	70	S980 045370
	3230	3880	75	S980 045384
	3450	4140	80	S980 045479
	3660	4400	85	S980 045480
	3790	-	88	S980 045383
	3880	-	90	S980 045481
	4310	-	100	S980 045483

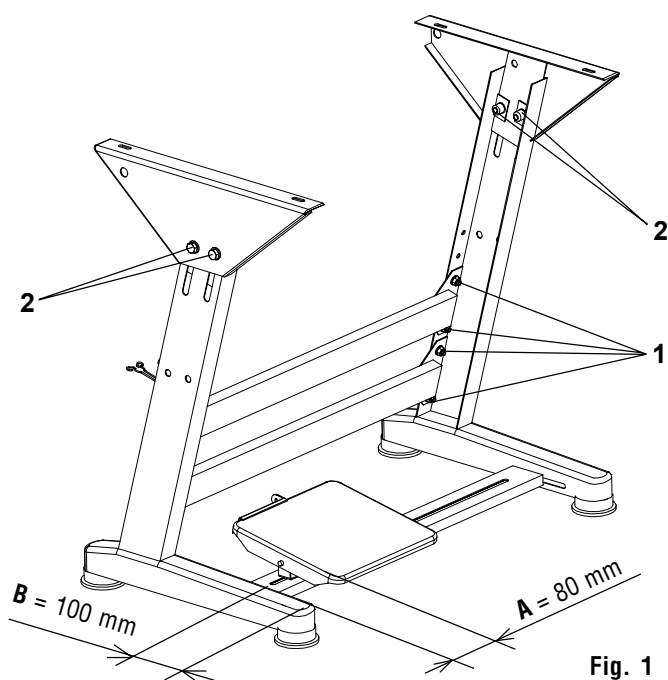

Fig. 1

## 3. Stand table top

For the event when the customer will ensure his own stand table top, its drawing is given on the page 4 (Fig. 5).

## 4. Assembly of the stand frame and height setting (Fig. 1)

Proceed to the assembly of the stand frame according to the Fig. 1. The dimension "B" is destined for a middle-high stature of the machine attending person. For a higher stature it is necessary to increase the dimension "B" and inversely. The machine feet are to be levelled with the floor in loosening the screws (1). Using the screws (2) it is possible to set up the height of the stand table top.

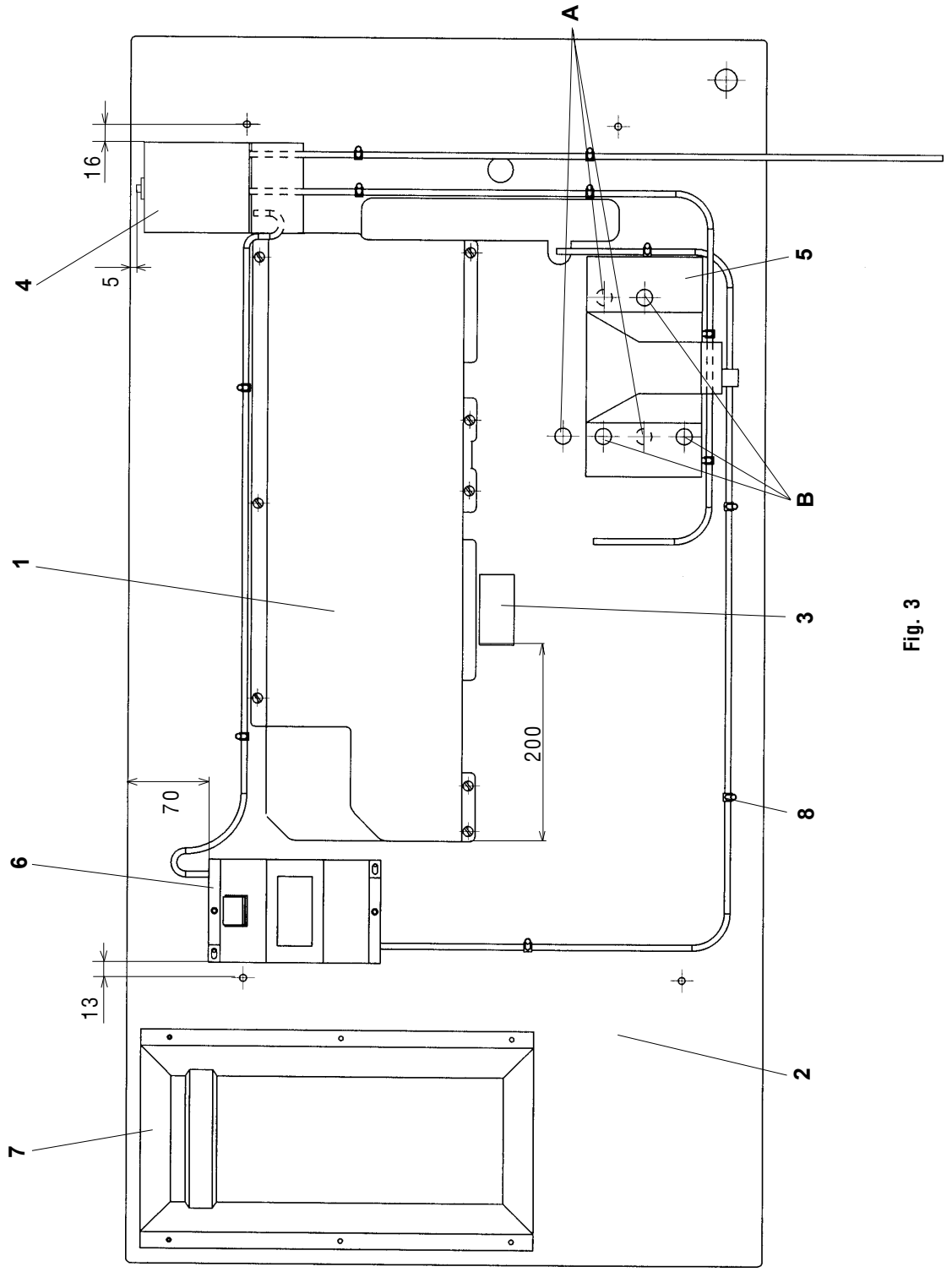

Fig. 3

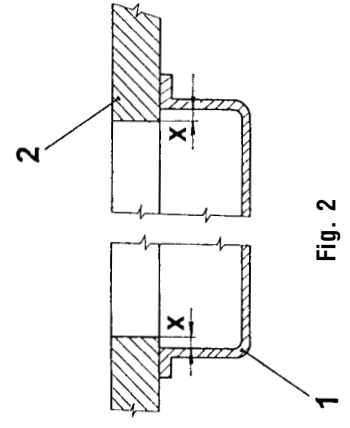

Fig. 2

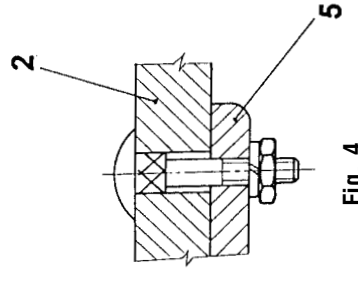

Fig. 4



## 5. Assembly and screwing on of the stand table top

### 5.1 Assembly of stand table top (Fig. 2, 3, 4, 5)

Put the rubber inserts for placing the machine head into the stand table top into the recess (2 and 3, Fig. 5). For better fastening, we recommend to stick on the inserts. When mounting the tray (1, Fig. 2) be sure in maintaining the distance "X" on the whole perimeter of the tray between the interior of the tray and the perimeter of the stand table top recesss (2).

Screw on the main switch (4) on the stand table top (2, Fig. 3).

Fasten the rubber bumper (3, Fig. 3).

Screw on the motor holder (5) according to the Fig. 3 and 4.

Screw on the lighting transformer (6, Fig. 3) for the lighting – if delivered.

Install electric conductors using clamps (8, Fig. 3) Connection differs according to the given motor, supply voltage and according to the number of conductors of the electric supply. In case of a four-conductor 3 x 400 supply the lighting transformer must be fed by a separate lead-in cable 1 x 230 V – see par. 12.3.

Screw on the drawer (7, Fig. 3).

In its working and tilted position, the machine head should not be in contact with the tray. The motor pulley diameter must comply with the maximum prescribed revolutions of the given type of the sewing machine and of the used motor. Adjust the motor circuit-breaker current according the nominal current given on the motor plate.

#### 5.1.1 Mounting and placing of the machine head on the stand (Fig. 8)

The machine head is in each case supplied with fitted hinges and with a lower cover metal plate meant only for the machine transport. Do not omit to remove the plate before setting the machine head on its stand. Place the machine head into the stand table top.

Put the supporting pin, which is included in the accessory of the machine, into the hole (7).

Mount the thread guides on the machine head.

#### 5.1.2 Assembly of motor pulley, belt, belt covers (Fig. 6)

Assemble motor pulley (2).

Insert V-belt (3) and tighten it by leaning out of the motor. V-belt is tightened correctly when the opposite sides of belt are approaching to each other in distance of about 20 mm with power 10 having an effect in the middle of both sides. Stop motor should be leveled so that the bottom surface of its control panel would be horizontal.

Adjust the stop (4) by bigger pulleys against falling the belt out of the pulley so that the distance from the belt will be 2-3 mm. Adjust pins by smaller pulleys (5) according to the detail (D).

Assemble the bottom cover belt (7) on to the motor.

Assemble upper cover belt (6) by clutch lever motor.

Assemble upper cover belt (6) and position reader by stop motor but only after electrical connection of the head to the stopmotor.

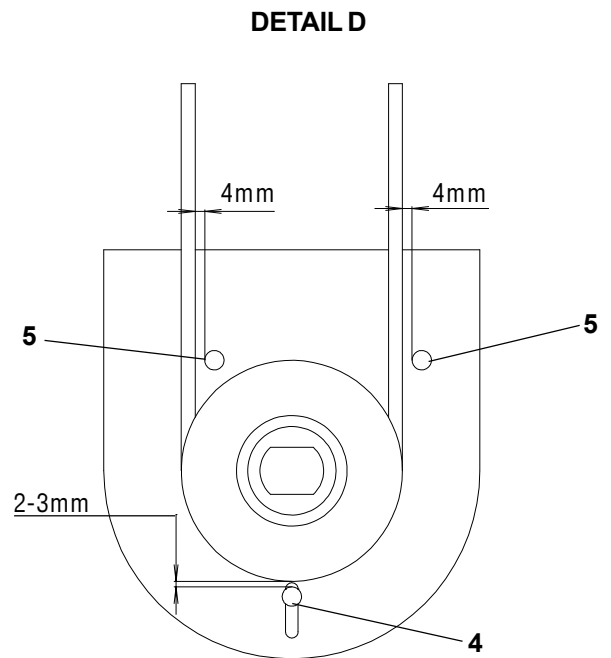
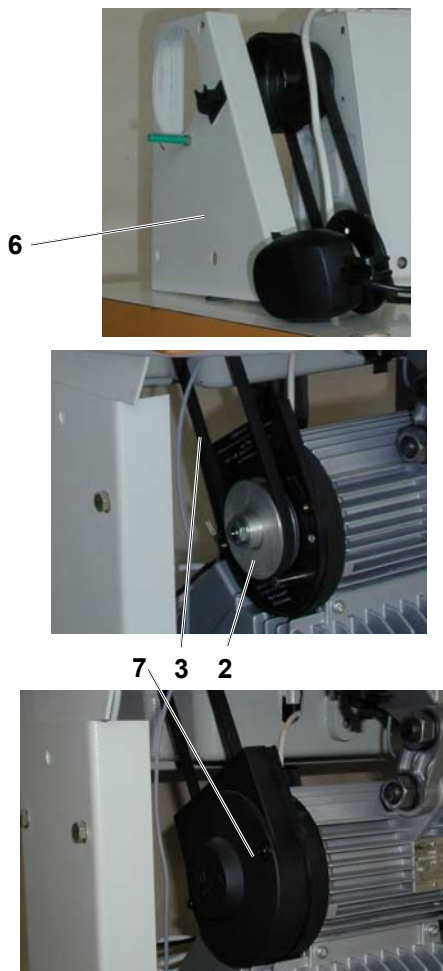

Fig. 6

## 6. Mounting of a position reader and of a control panel of the stop motor (Fig. 7, 8)

Put the position reader (2) on the pin of the hand wheel in such a way, so that the arresting groove of the reader is placed on the arresting stop (4) (in this way, the movement of the position reader body is avoided). Fasten the reader in tightening two screws with an inner hexagon.

With the EFKA stop motor, mount the control panel V 810 (1) onto the upper guard using two screws (3) which are situated on the guard.

With the EFKA stop motor, mount the holder (5) to the panel V 820 (6) using a screw and screw on the holder with the panel to the machine table top.

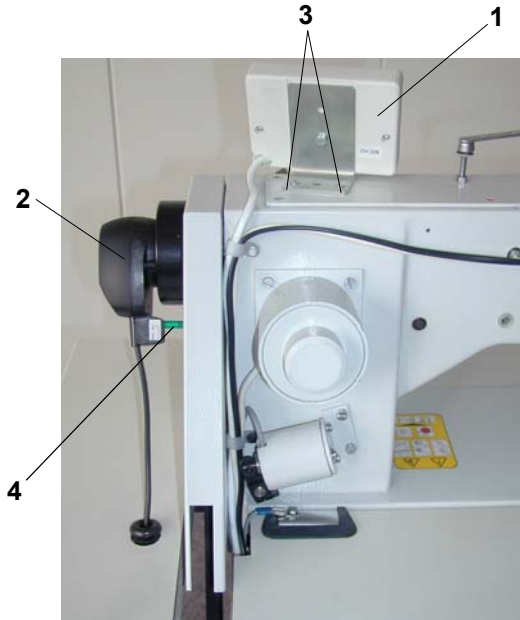

Fig. 7

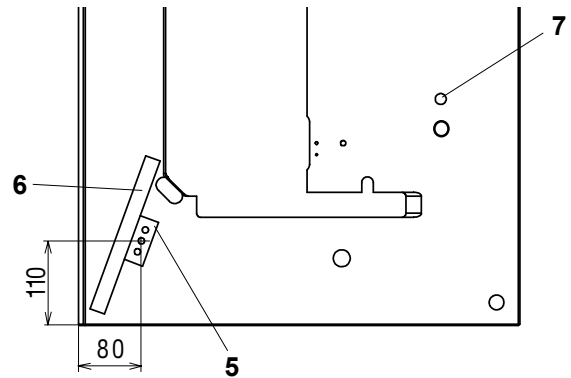

Fig. 8

## 7. Mounting of the equipment for presser foot lifting using electromagnet (Fig. 9, 10)

Loosen the lever (1), remove the spring with the lever (for mechanical presser foot lifting) and mount the spring (2) and the lever (3). Set up the lever (1).

Mount the magnet (4) with the plate (5) using the screws (6) on the machine head according to the given illustrations.

Set the position between the lever (3) and the core of the electromagnet (4) - minimum clearance – presser foot in its bottom dead centre.

Through the slot in the plate connect the magnet to the outlet on the interconnecting cable of the motor and of the head - see par. 12.4.

Remove the supporting pin from the table top (Fig. 8, pos. 7), insert the cover caps (7) into the holes.

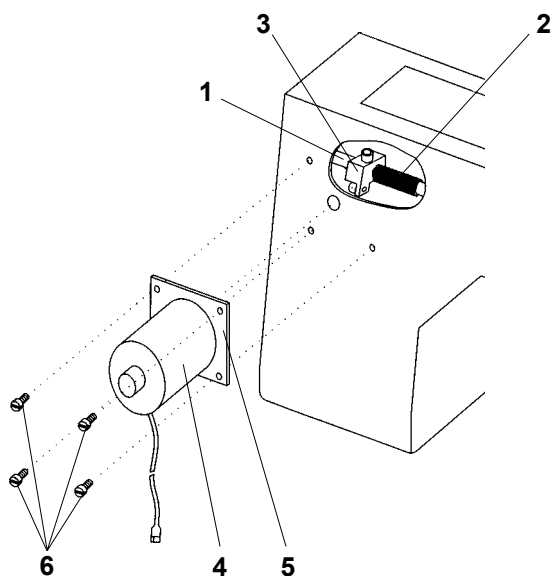

Fig. 9

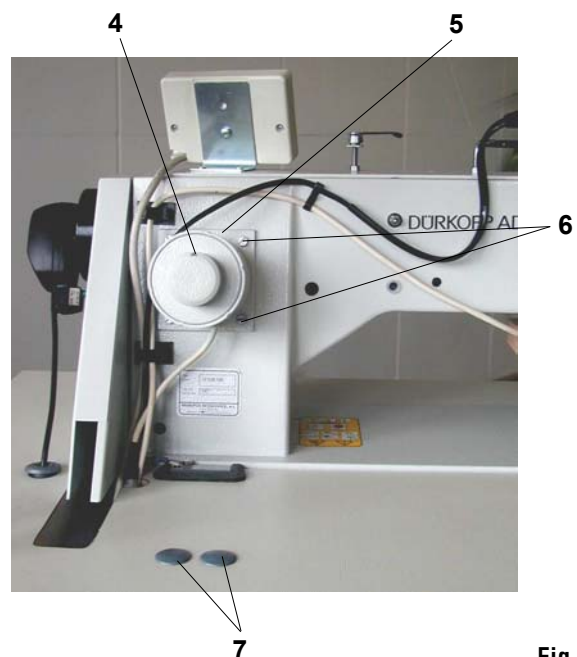

Fig. 10

## 8. Mounting of the equipment for backward stitching (Fig. 11, 12)

Remove the backward stitching lever and the knob for setting the stitch length.

Mount the knob (1) and the shaft (2).

Put on the lever (3) with the magnet (4) on the shaft (2) and fasten the magnet with screws (5) to the machine arm. Using the screw (6), fasten the lever (3) on the shaft (2).

Connect the magnet conductor through the cutout in the table top into the outlet on the motor and head interconnecting cable. - see par. 12.4.

Using the screws (7), fasten the push button holder (8) to the machine arm. Fasten then the conductor using the clips (9) to the machine arm.

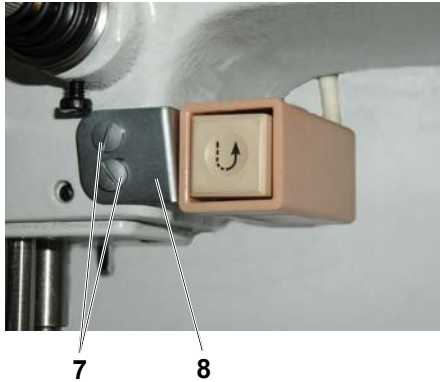

Fig. 11a



Fig. 11b

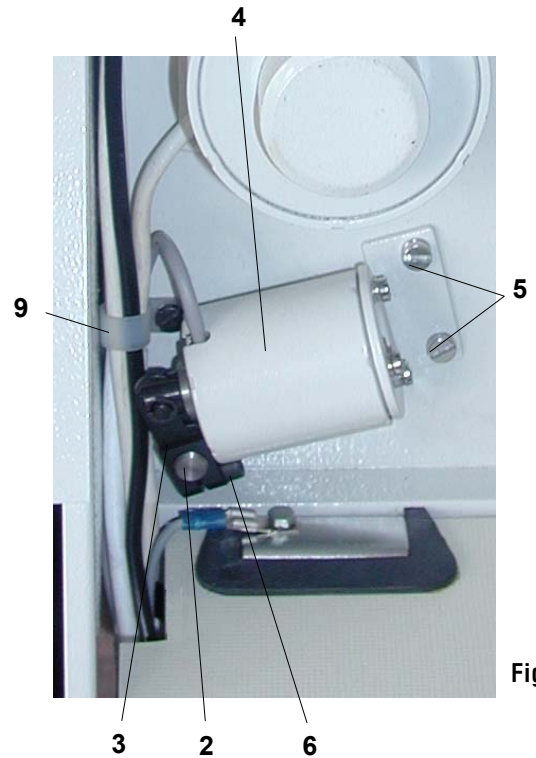

Fig. 12

## 9. Mounting of the lighting (Fig. 13, 14)

Screw on the roller (2) using the screw (1) on the machine head, put on the lighting on the roller (2) and tighten it with the crank-handle (3).

The assembling procedure of the transformer is described in par. 5.1.



Fig. 13

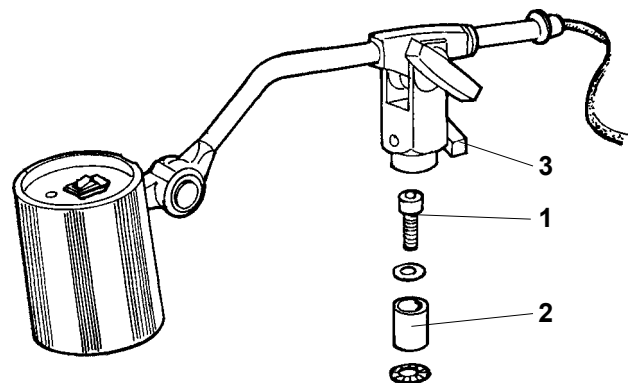

Fig. 14

## 10. Composition and assembly of the thread stand (Fig. 15, 16)

Assemble the thread stand and mount it into the hole in the plate so that its arms would be parallel to the longer edge of a table top.

Each thread may be fed only through one hole in the thread stand arm.

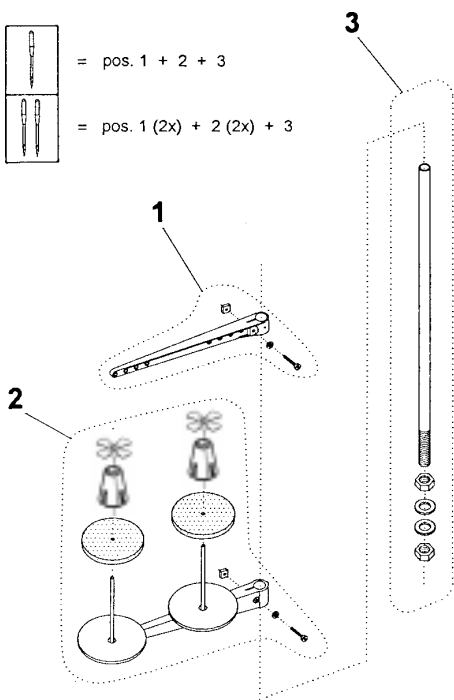

Fig. 15

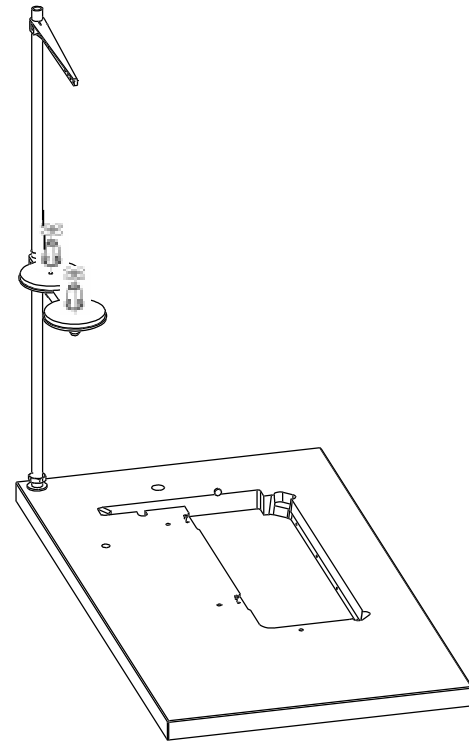

Fig. 16

## 11. Preparation of the machine for sewing

Inspect carefully the machine, clean and try it, if it turns easily and if it is correctly adjusted.

Fill with oil the oil tank for lubricating the hook and for the central wick-feed lubrication – the lubricating spots are marked with red colour on the machine (part A, par. 7.2 - Fig 12, 13).

For lubricating, use oil ESSO SP-NK 10 or an oil with an equivalent quality. Connect the machine to the mains.

With the sewing drives with three-phase motor, check up the direction of the motor rotation through a short-run connecting of the motor switch. The direction of the machine rotation is marked with an arrow on the belt guard.

In case of an incorrect direction of rotation, inverse mutually two phases in the mains plug. Before utilizing the machine in full power, let run it for some minutes on low speed.

## 12. Instructions for putting the electronically controlled drive into operation

When putting these drives into operation, observe the hints mentioned in the accompanying documentation of the manufacturer of this drive. The inobservance of these hints may cause damage of the drive or of the sewing machine head.



### Caution!

The voltage in the mains must comply with the voltage given on the drive plate.



### Caution!

The lighting transformer is not switched off by the main switch (EN 60204-3-1). When proceeding to a repair in the transformer box (e.g. replacement of fuses), it is absolutely necessary to disconnect the mains plug from the mains! Such operations may be carried out only by workers having the respective electrotechnical qualification.

Choose the suitable connection variant according to the following figures:

### 12.1 Power supply 1 x 230 V - DC motor

Circuit layout - Evropa

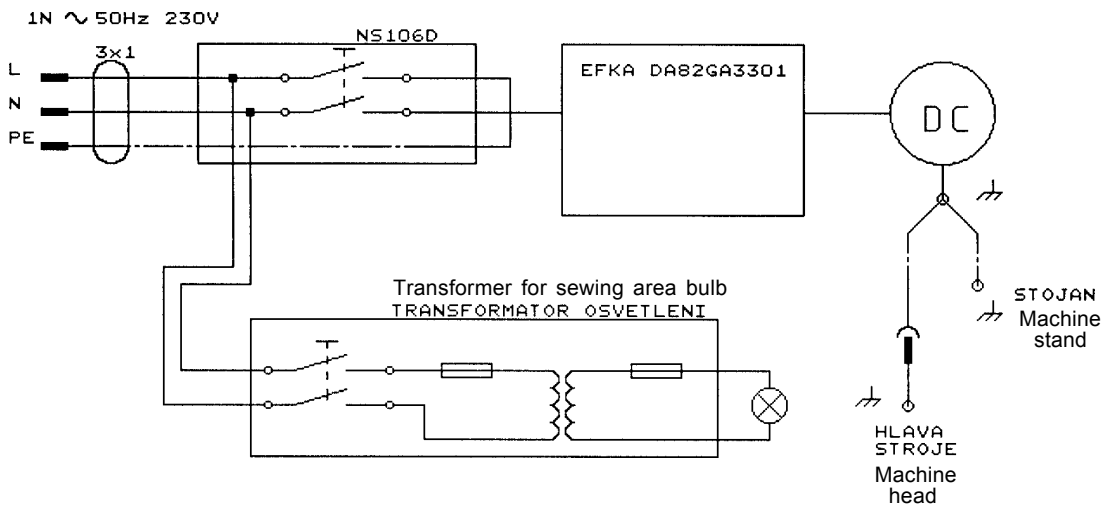

Circuit layout - Amerika

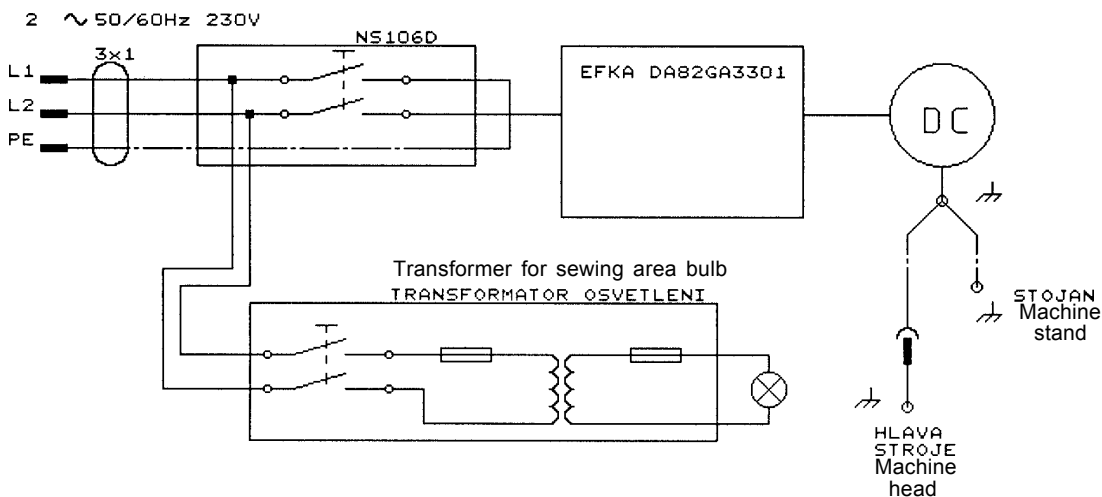

## 12.2 Power supply 3 x 400 V - five wire power distribution, power supply 3 x 230 V - four wire or five wire power distribution

Circuit layout - Evropa

3N ~ 50Hz 400/230V

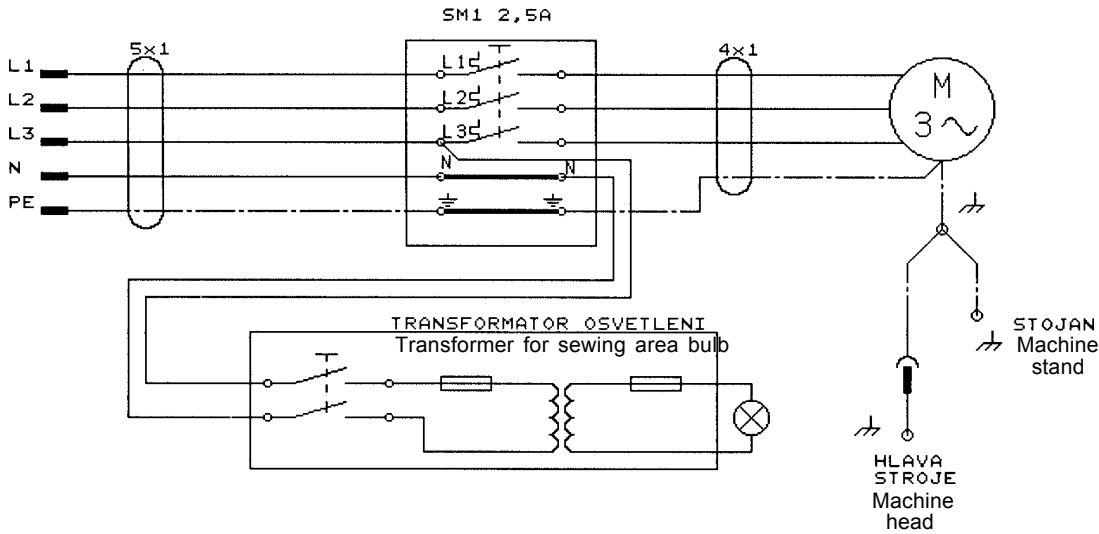

Circuit layout - Amerika

3N ~ 50Hz 400/230V

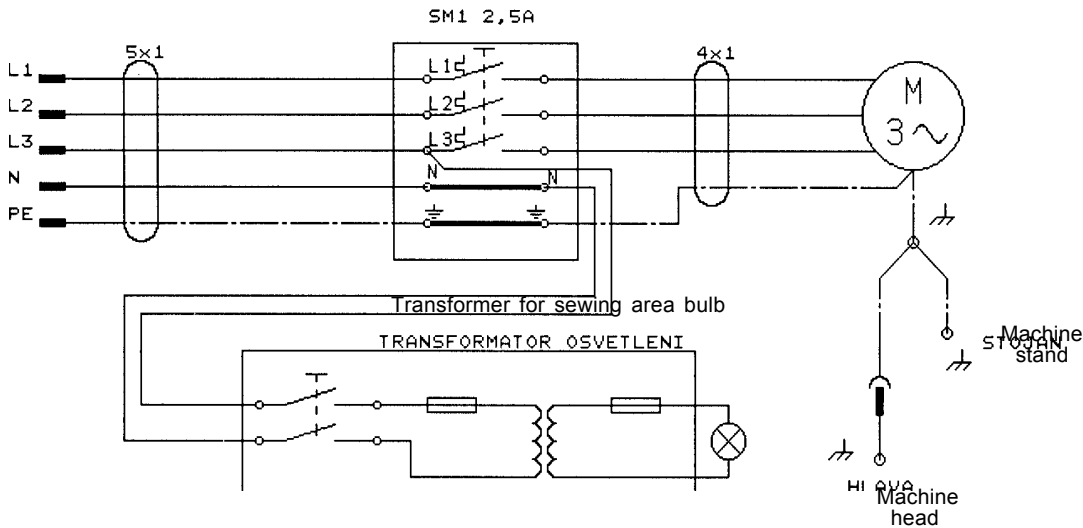

## 12.3 Power supply 3 x 400 V - four wire power distribution plus 1 x 230 V - two wire cable

Circuit layout

3 ~ 50Hz 400V

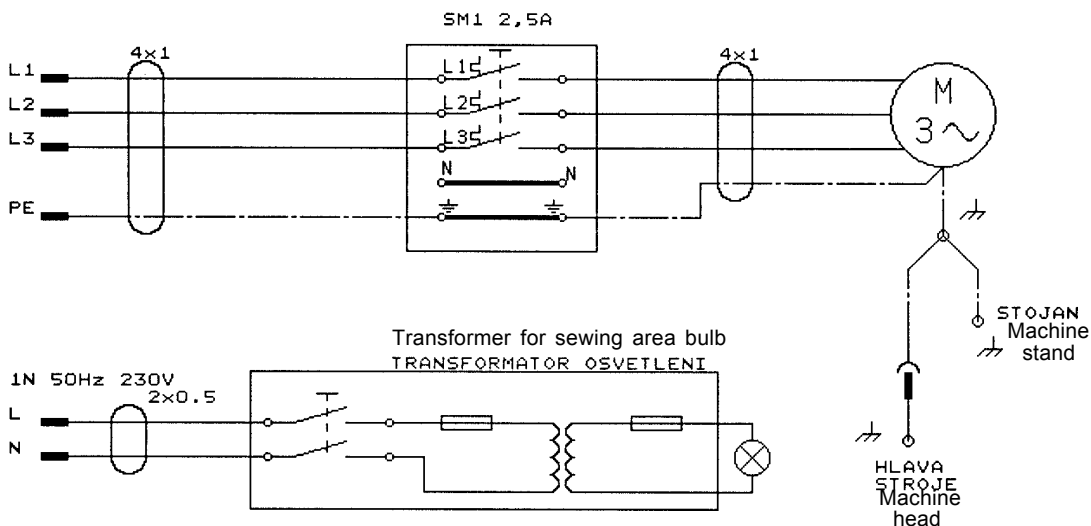

## 12.4 Electrical connection of machine head to the stop motor

Stop motor S359 600045 XXX - EFKA DC 1600/DA82GA

Circuit layout

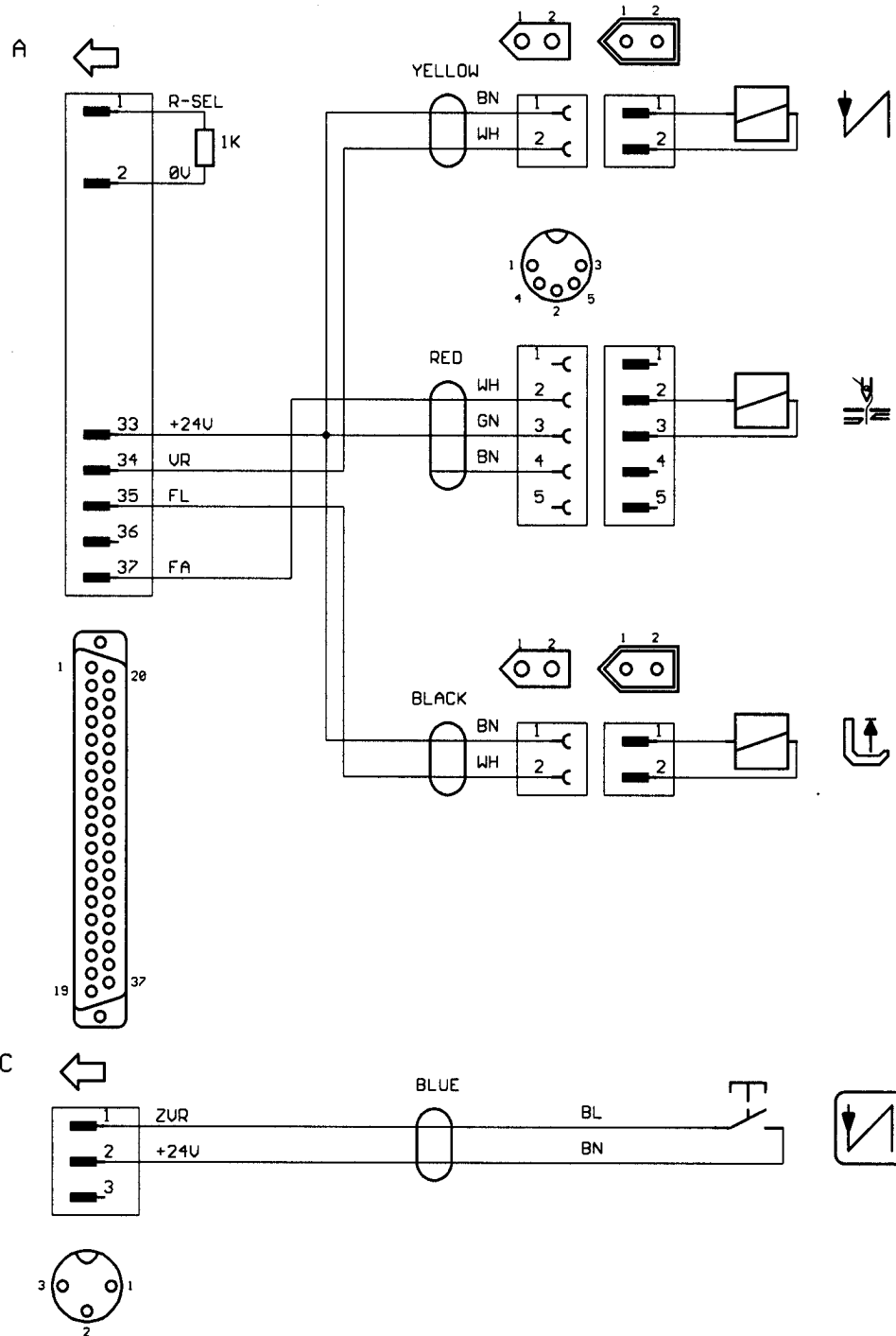

Stop motor S359 600052 XX - EFKA VD 552/6F82FA

Circuit layout

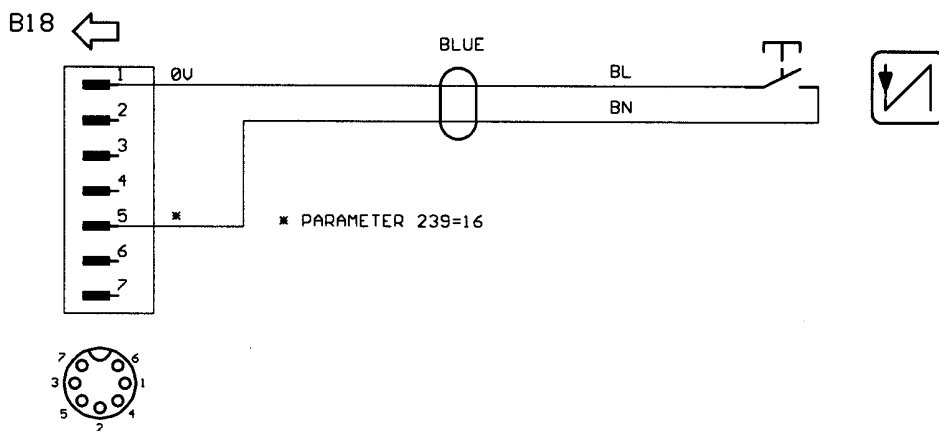
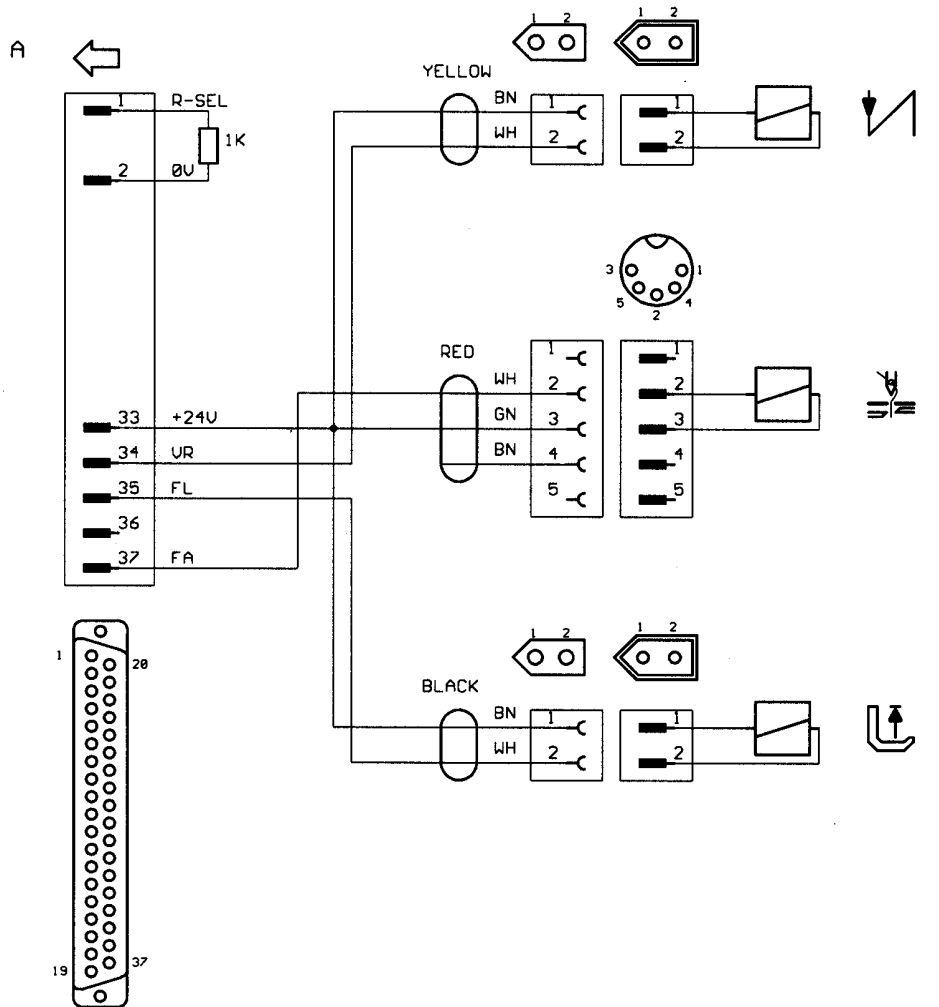

## 12.5 Stop motor setting S359 600045 XXX - EFKA DC 1600/DA82GA

### 12.5.1 Setting position reader

- set the parameter **170**, the display will show **Sr1** (reference position)
- depress the pushbutton **>>**, the display will show **PoS 0** and the changing rotation symbol
- turn the hand wheel until the rotation symbol disappears
- turn the hand wheel in such a way, so that the needle point, when moving downward, is on the level of the throat plate
- depress the pushbutton **E** and pass to the parameter **171**
  
- set the parameter **171**, the display will show **Sr2** (all positions)
- depress the pushbutton **>>**
- the display will show **1 XXX** (value of the bottom position)
- turn the hand wheel, until the value **XXX** begins to change
- turn the hand wheel at the value of the bottom position angle (**160** on the panel)
- depress the pushbutton **E**
- the display will show **2 XXX** (value of the top position)
- turn the hand wheel, until the value **XXX** begins to change
- turn the hand wheel at the value of the top position angle (**460** on the panel)
- depress the pushbutton **P 2x** (return to the sewing mode)
- tread shortly forward the pedal (memory entry)

### 12.5.2 Changes of setting parameters of stop motor setting considering original producer setting

Parameter No	Parameter value	
111	-	Max. revolutions (according to a type of machine)
170	-	Reference position
171	1 160	Lower position
	2 460	Upper position
190	300	Switch on angle of thread trimmer (210°)
202	120	Delay of start run after switch off the signal foot
210	200	Stopping time for fancy bar
213	5	Time off full power of backtacking

## 12.6 Stop motor setting S359 600052 XX - EFKA VD 552/6F82FA

### 12.6.1 Setting position reader

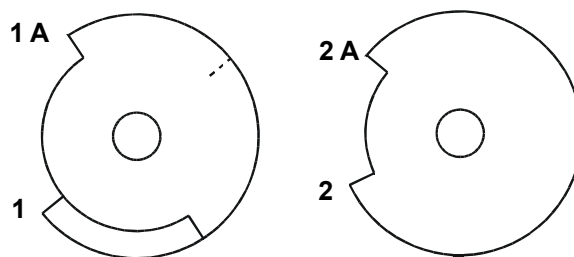

Positions are set by means of discs with cut outs directly in position reader.

#### Setting of the lower position:

- dismount the guard of the position reader
- switch on the mains switch
- tread shortly pedal forward (the machine stops in the needle lower position)
- switch off the mains switch
- turn the beginning of the recess **1** of the overlapping disks in such a way, so that the machine stops with the needle in the position of 3 mm behind the bottom dead center
- check up in repeating the procedure

#### Setting of the top position of the thread lever:

- tread the pedal rearward (the machine stops in the needle upper position)
- switch off the mains switch
- turn the beginning of the recess **2** in such a way, so that the machine stops with the thread lever in the top dead centre
- check up in repeating the procedure.

## 12.6.2 Changes in parameters of stop motor setting considering original producer setting

Parameter No	Parameter value	
111		Max. revolutions (according to a type machine)
190	100	Switch on angle of thread trimmer
202	120	Delay of start run after switch off the signal foot
210	200	Stopping time for fancy bar
213	5	Time off full power of backtacking
239	16	Function of the pushbutton on B 18/5